

Installation, Operation and Service Instructions

RADIANT TUBE HEATERS



SUPERIOR
RADIANT PRODUCTS

SERIES EUA TWO STAGE

CE 0085

UK
CA 0086

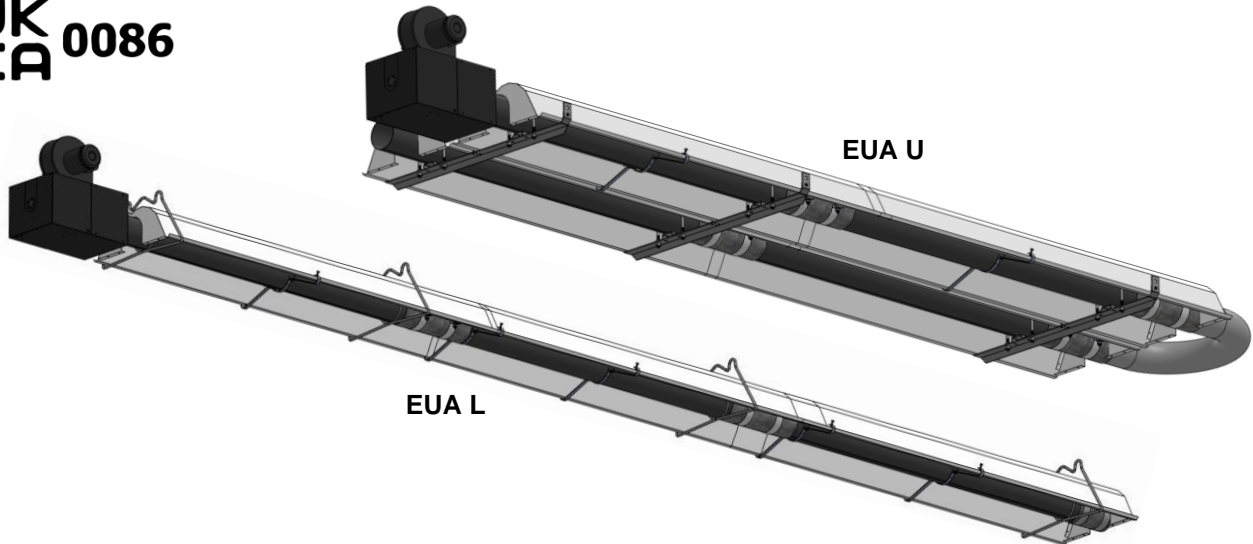

WARNING

Improper installation, adjustment, alteration, service, or maintenance can cause property damage, injury or death. Read the installation, operation, and service instructions thoroughly before installing or servicing this equipment.

FOR YOUR SAFETY

Do not store or use flammable vapors and liquids in the vicinity of this or any other appliance.

If you smell gas:

1. Open windows
2. Don't touch electrical switches
3. Extinguish any open flame
4. Immediately call your gas supplier

OWNER

Retain this Manual & ensure available for service. Improper installation, adjustment, alteration, service, or maintenance can cause injury, death or property damage. Read the installation, operation, and service instructions thoroughly before installing or servicing this equipment

INSTALLER

Provide Manual to Owner upon completion of installation!

Read and thoroughly understand these Instructions before attempting any installation

Canada: 563 Barton Street, Stoney Creek, Ontario L8E 5S1

USA: 315 N Madison Street, Fortville, IN 46040

www.superiorradiant.com

CAUTION: FIRE OR EXPLOSION HAZARD

Maintain clearance to combustible constructions as further specified in this manual. Failure to do so could result in a serious fire hazard. Heaters should not be located in hazardous atmospheres containing flammable vapors or combustible dusts. Signs should be provided in storage areas specifying maximum safe stacking height.

CAUTION: MECHANICAL HAZARD

This equipment expands and contracts with each operating cycle. The gas connection, suspension hardware, and the installation itself must safely allow this movement. Failure to do so could result in serious fire or explosion hazard.

CAUTION: FIRE OR EXPLOSION HAZARD

This heater is equipped with an automatic ignition device. Do not attempt to light the burner by hand. Failure to comply could result in a serious fire and personal injury hazard.

CAUTION: MECHANICAL HAZARD

Do not use high pressure (above 60 mbar) to test the gas supply system with the burners connected. Failure to do so could result in damage to the burner and its control components requiring replacement.

CAUTION: SERVICE LIFE RISK

Do not install equipment in atmosphere containing halogenated hydrocarbons or other corrosive chemicals. Failure to do so may lead to premature equipment failure and invalidation of the warranty. Additionally, it is recommended that the equipment be installed with a downward slope, away from the burner. The rate of declination should be 6mm (¼") in height per 3m (10') in length to allow the start-up condensation to drain.

CONTENTS

INTRODUCTION	4
CODES AND REGULATIONS	4
GENERAL SPECIFICATIONS	5
GAS SUPPLY	5
ELECTRIC SUPPLY.....	5
VENTING AND COMBUSTION AIR	5
CONFIGURATIONS	5
DIMENSIONAL CHARTS	6
PACKAGING CONTENTS – EUA L	7
GENERAL ASSEMBLY – EUA L.....	7
PACKAGING CONTENTS – EUA U	8
GENERAL ASSEMBLY – EUA U	8
GENERAL ASSEMBLY – BURNER BOX	9
CLEARANCES TO COMBUSTIBLES	10
HANGERS INSTALLATION AND HEATER SUSPENSION	11
VENTING & COMBUSTION AIR	12
GENERAL REQUIREMENTS	12
UN-VENTED OPERATION	12
COMBUSTION AIR SUPPLY.....	13
SUPPLYING FRESH AIR	14
GAS SUPPLY	15
GENERAL REQUIREMENTS	15
ELECTRICAL WIRING	16
GENERAL REQUIREMENTS	16
INTERNAL WIRING DIAGRAM	16
AIR PRESSURE SWITCH	18
BURNER OPERATION	18
STARTING SEQUENCE OF OPERATION	18
MAINTENANCE	18
ASSEMBLY INSTRUCTIONS SEQUENCE – EUA L	19
ASSEMBLY INSTRUCTIONS SEQUENCE – EUA U	24
SIDE REFLECTORS	33
COMMISSIONING	34
TROUBLESHOOTING	35
CONVERSION INSTRUCTIONS	37
REPLACEMENT PARTS	38
REPLACING PARTS	39
TECHNICAL DETAILS	42
TECHNICAL DETAILS – ERP DIRECTIVE	43
NOTES	44
WARRANTY	45

INTRODUCTION

Superior Radiant Products is a company in the infrared heating industry founded on the principles of product quality and customer commitment.

Quality commitments are evidenced by superior design, a regard for design detail and an upgrade of materials wherever justifiable.

Customer commitment is apparent through our ready responses to market demands and a never ending training and service support program for and through our distributor network.

Superior Radiant offers more than 25 years of infrared expertise in a cost effective unitary heater design as culmination of that commitment.

Series EUA model is a low intensity infrared two stage tube heater with high radiant and thermal efficiency.

Important

The manufacturer's instructions, the layout drawing, national and local codes and ordinances, and all applicable standards which apply to gas piping and electrical wiring comprise the basic information needed to complete the installation. These criteria must be thoroughly understood before proceeding.

Only personnel who have been trained and understand all applicable codes should undertake the installation.

Codes and Regulations

Series EUA radiant tube heater is designed and manufactured according to EN 416 "Single burner gas-fired overhead radiant tube heaters for non-domestic use".

This appliance must be installed in accordance with the rules in force. It shall be used in a space ventilated in accordance with the requirements of EN 13410 Gas-fired overhead radiant heaters - Ventilation requirements for non-domestic premises. Consult the instructions before installation and use of this appliance.

Every heater is subjected to a function test prior to leaving the factory and is pre-set for the relevant type of gas. The following regulations and directives are to be considered for the installation and operation of radiant heating systems.

EN 60335-1, Household and similar electrical appliances - Safety - Part 1: General requirements

EN 60335-2-102: Household and similar electrical appliances - Safety - Part 2-102: Particular requirements for gas, oil and solid-fuel burning appliances having electrical connections.

EN 12831, Heating systems in Buildings.

This heater is NOT approved for use in residential dwellings.

GENERAL SPECIFICATIONS

Gas Supply

Supply Pressure

	Minimum	Nominal	Maximum
Natural Gas:	17.5 mbar	20 mbar	25 mbar
Propane:	28 mbar	37 mbar	50 mbar

Manifold Pressure

	Nominal Heat Input	Partial Heat Input
Natural Gas:	12.5 mbar	8 mbar
Propane:	25 mbar	15.5 mbar

Inlet Connection

1/2" female BSP

Electric Supply

Alternating current: Voltage 230 V, 50 Hz with L, N and PE

Power consumption: 70 W, 0.3A

Venting and Combustion Air

Flue Diameter: 100 mm

Air inlet connection: 100 mm

CONFIGURATIONS

		Model EUA L						Model EUA U				
Natural gas		10	20	30	40	50	60	20	30	40	50	60
Heat Input	kW gross	11	22	30	43.5	52.5	61	22	30	43.5	52.5	61
Partial Heat Input	kW gross	8.5	17	23	32	39.5	44.5	17	23	32	39.5	44.5
Propane		10	20	30	40							
Heat Input	kW gross	10.5	21.5	29.5	40	21.5	29	40				
Partial Heat Input	kW gross	8.5	16.5	23	31	16.5	23	31				

DIMENSIONAL CHARTS

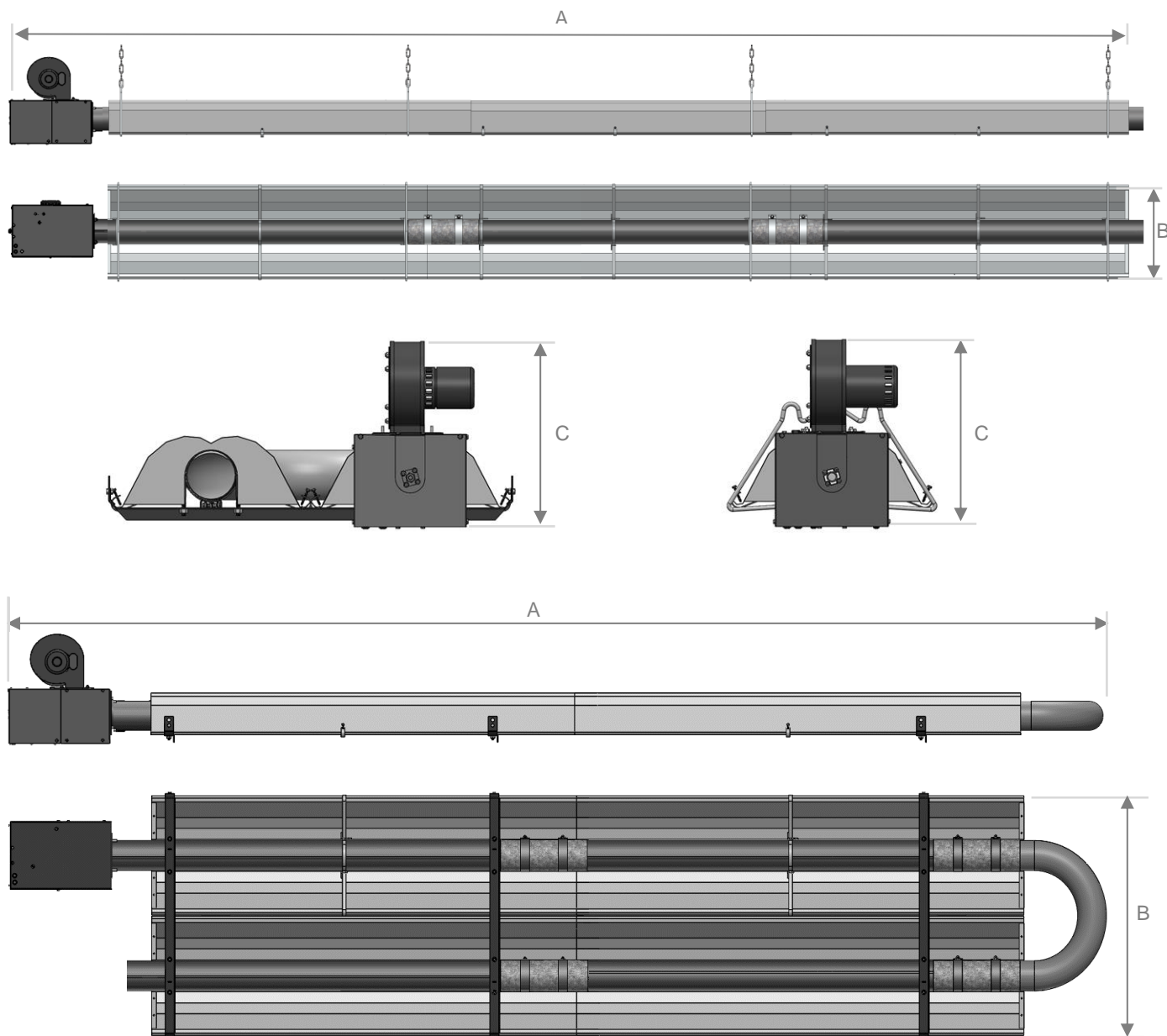

Figure 1: Overall Dimensional Information

Model EUA L	Units	10	20	20S	30	40	50	60
Dimensions								
A	mm	3400	9500	7975	9500	12550	18650	21700
B	mm	400	400	400	400	400	400	400
C	mm	400	400	400	400	400	400	400
Weight	kg	46	64	50	64	80	112	127

Model EUA U	Units	20	20S	30	40	50	60
Dimensions							
A	mm	5400	3875	5400	6950	10000	11480
B	mm	900	900	900	900	900	900
C	mm	390	390	390	390	390	390
Weight	kg	66	52	66	82	114	129

PACKAGING CONTENTS – EUA L

Get to know your heater parts (list referencing Figures 2 & 4).

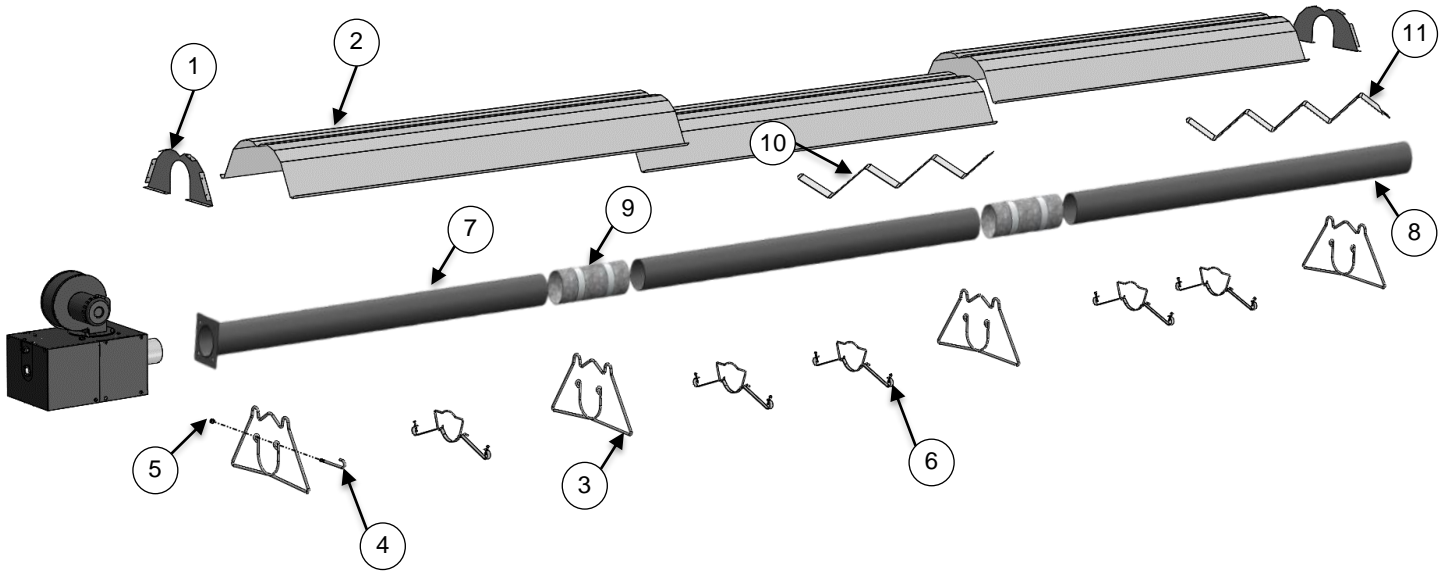

Figure 2: General Overview EUA L

General Assembly – EUA L

No.	PN	Description	Model						
			10	20S	20	30	40	50	60
			Quantities						
1	CR002	End Cap	2	2	2	2	2	2	2
2A	CR001	Reflector, 3150mm (124")	1	2	3	3	4	6	7
2B	CR031	Reflector, 1575mm (62")	0	1	0	0	0	0	0
3	CR003	Hanger	2	4	4	4	5	7	8
4	CH218	J Bolt, M8	1	1	1	1	1	1	1
5	CH223	Nut, M8	1	1	1	1	1	1	1
6	CR024	Reflector Bracket Assy	1	4	5	5	7	11	13
7	UT002	Flanged Tube, 3050mm (120")	1	1	1	1	1	1	1
8A	CT001	Tube, 3050mm (120")	0	1	2	2	3	5	6
8B	CT073	Tube, 1525mm (60")	0	1	0	0	0	0	0
9	CR010	Coupling (12")	0	2	2	2	3	5	6
10	CT006	Turbulator, SS, 1830mm (6')	0	1	1	1	1	0	0
11	CT007	Turbulator, Alz., 1830mm (6') w/ Tab	0	1	1	1	1	0	0
12	CT016	Turbulator, SS, 1830mm (6') w/ Tab <i>(not shown)</i>	1	0	0	0	0	0	0

PACKAGING CONTENTS – EUA U

Get to know your heater parts (list referencing Figures 3 & 4).

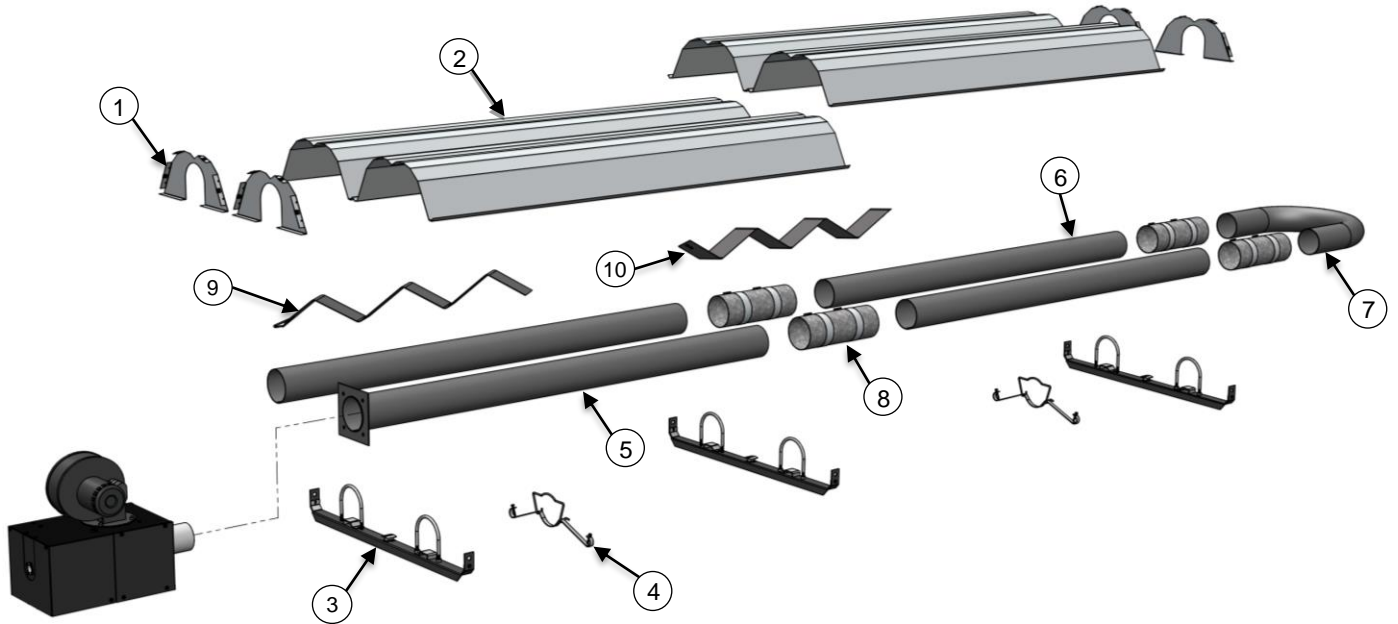

Figure 3: General Overview EUA U

General Assembly – EUA U

No.	PN	Description	Model					
			20S	20	30	40	50	60
			Quantities					
1	CR002	End Cap	4	4	4	4	4	4
2A	CR001	Reflector, 3150mm (124")	2	2	2	4	6	6
2B	CR031	Reflector, 1575mm (62")	0	2	2	0	0	2
3	CR158	Hanger Kit	2	3	3	3	4	5
4	CR024	Reflector Bracket Assembly	1	1	1	2	3	3
5	UT002	Flanged Tube, 3050mm (120")	1	1	1	1	1	1
6A	CT001	Tube, 3050mm (120")	1	1	1	3	5	5
6B	CT073	Tube, 1525mm (60")	0	2	2	0	0	2
7	CT120	U-Tube	1	1	1	1	1	1
8	CR010	Coupling (12")	2	4	4	4	6	8
9	CT007	Turbulator, Alz., 1830mm (6') w/ Tab	1	1	1	1	0	0
10A	CT006	Turbulator, SS, 1830mm (6')	0	1	1	1	0	0
10B	CT132	Turbulator, SS, 1220mm (4')	1	0	0	0	0	0
-	CT165	Turbulator, SS, 610mm 2' w/ Tab <i>(not shown)</i>	1	0	0	0	0	0

CLEARANCES TO COMBUSTIBLES

A general clearance of 500 mm (20") in every direction is recommended for servicing. In addition to this, it is very important to observe the minimum clearances to combustibles at all times to avoid any possibility of property damage or personal injury.

WARNING

- Maximum allowable stacking height in storage areas should be identified with signs or appropriate markings adjacent to the thermostat or in a conspicuous location.
- Clearances to combustibles DO NOT indicate acceptable distances from PVC paneling. Refer to panel manufacturers recommendations.

Combustible materials are considered to be wood, compressed paper, plant fibres, plastics, Plexiglas, or other materials capable of being ignited and burned. Such materials shall be considered combustible even though flame-proofed, fire-retardant treated, or plastered.

Adequate clearance to sprinkler heads must be maintained.

The stated clearance to combustibles represents a surface temperature of 50°C above room temperature. **It is the installer's responsibility to ensure that adjacent materials are protected from deterioration.**

	Below	Side	Above Reflector	End	Front	Rear
	A	B	C	D	E	F
EUA L 10, 20, 20S, 30, 40	1880 mm	910 mm	100 mm	500 mm	1630 mm	100 mm
EUA U 20, 20S, 30, 40	1930 mm	940 mm	100 mm	500 mm	1630 mm	100 mm
EUA L 50, 60	2030 mm	1120 mm	150 mm	500 mm	1830 mm	100 mm
EUA U 50, 60	2080 mm	1140 mm	150 mm	500 mm	1830 mm	100 mm

Table 1: Minimum clearances to combustibles

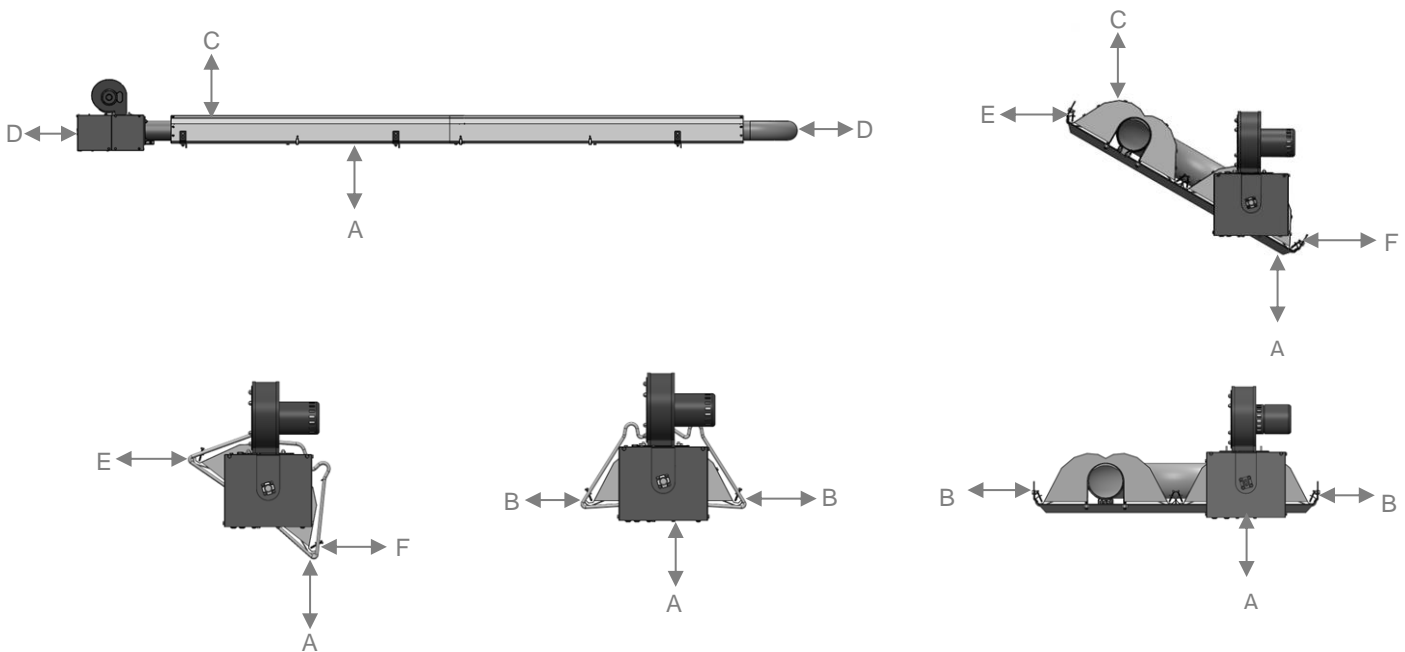

Figure 5: Clearances to Combustibles

HANGERS INSTALLATION AND HEATER SUSPENSION

- The heater should be installed in accordance with the relevant provisions of National Standards and Codes of Practice in the destination country.
- Suspension mechanism must allow for lateral tubing expansion. A minimum 300 mm (12") length welded link chain with a working load limit of at least 90 kg (200 lbs) is recommended (refer to Figure 5 for more details). **Manufacturer recommends and makes available "quick links" for connecting chain. If any open ended "S" hooks and turnbuckles are used, the open ends must be closed to avoid unhooking chain with inadvertent contact.**
- Locate hanging chain at predetermined suspension points in the structure.

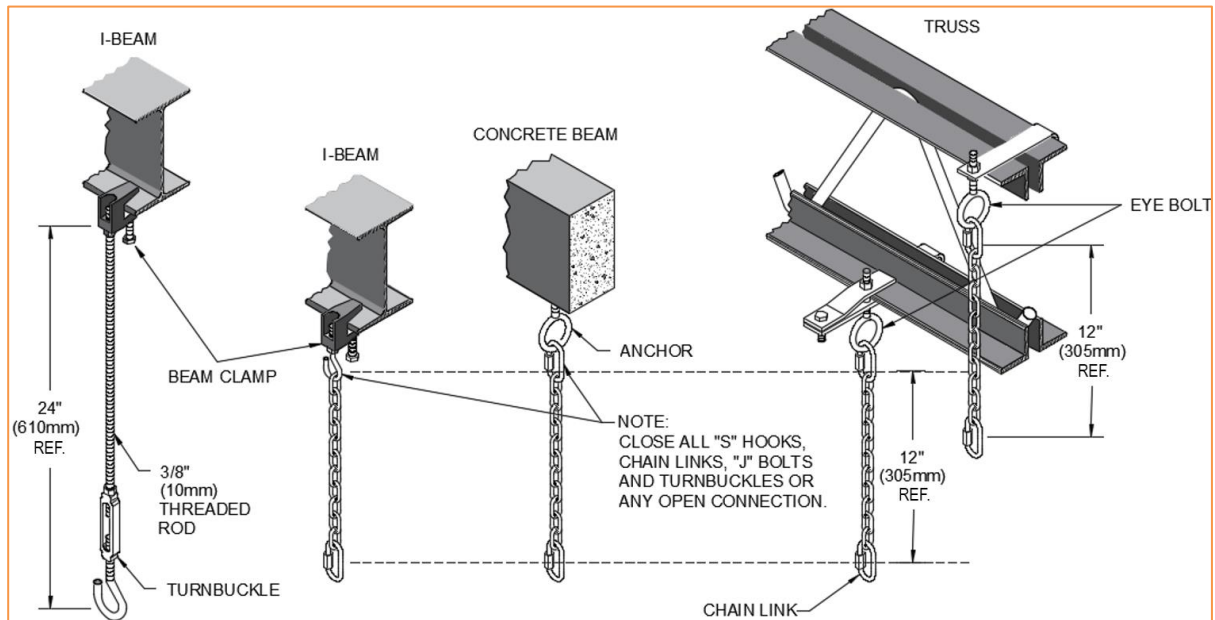

Figure 6: Suspension Mechanism

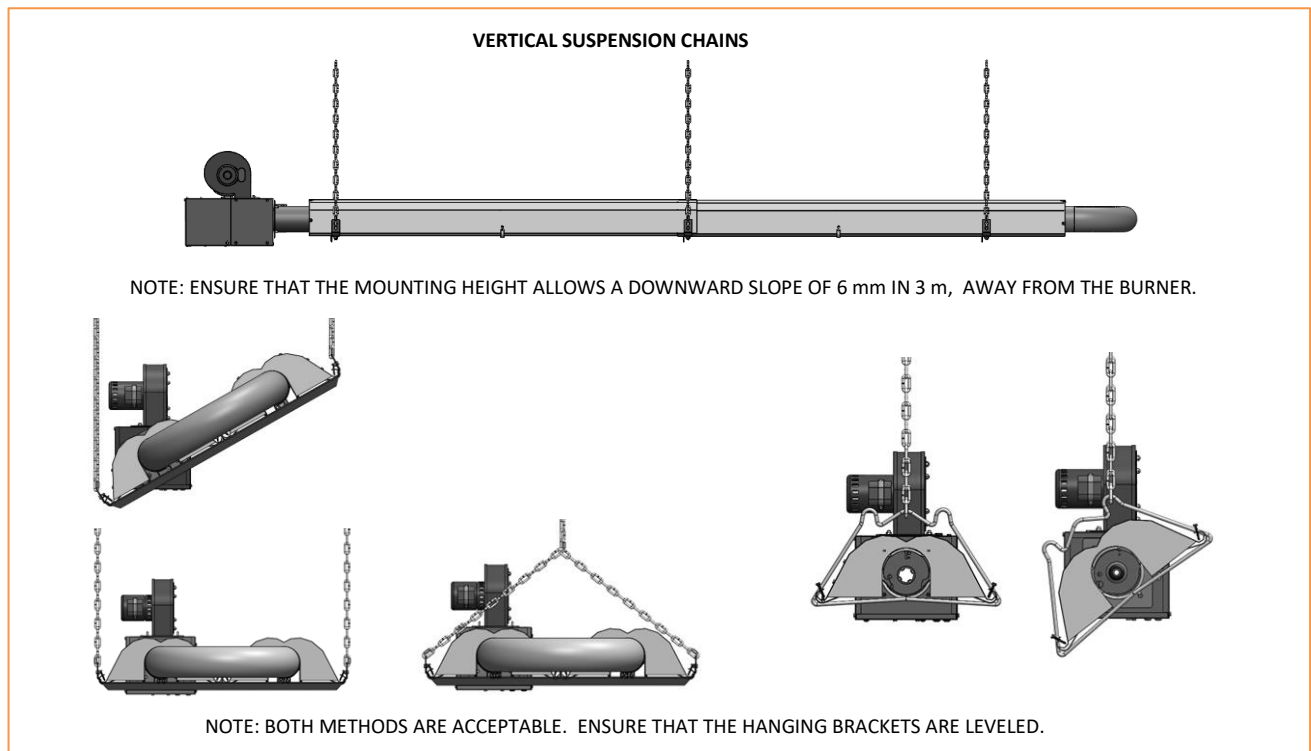

Figure 7: Heater Suspension

VENTING & COMBUSTION AIR

General Requirements

The heater should be installed in accordance with the relevant provisions of National Standards and Codes of Practice in the destination country.

Heaters can be operated according to the following appliance type:

- Type A3. Gas appliance without flue gas system. The combustion air is taken from the installation space.
- Type B23. Gas appliance with flue gas system, taking the combustion air from the installation space.
- Type C63. Gas appliance with flue gas system and outside (ducted) combustion air supply. Use a separated approved and marketed system for supply of combustion air and discharge of the combustion products.

Un-Vented Operation

The installation room should have a volume of at least $10\text{m}^3/\text{kW}$ of installed nominal heat input of the radiant heater. The ventilation requirements and calculation methods for unvented appliances are set out in the European Standards EN 13410:2001 and must be applied. The following is guidance to the standard:

Ventilation may be achieved by any of the three following different means:

- a) Thermal evacuation of the products of combustion/air mixture;
- b) Mechanical evacuation of the products of combustion/air mixture;
- c) Natural air change.

Ventilation by Thermal Evacuation

- a) The air of the room mixed with the products of combustion shall be evacuated above the radiant heaters, if possible near the ridge by means of exhaust air openings.
- b) Shut down devices and restrictors at exhaust air openings are permissible if an automatic safety device ensures opening of the devices/restrictors for the safe operation of the appliances. Otherwise exhaust air openings shall not be restricted or closed.
- c) The horizontal distance between a radiant heater and an exhaust air opening shall not exceed six times the exhaust air opening height (measured to the centre of the opening) for wall openings and three times the exhaust air opening height (measured to the centre of the opening) for roof openings.
- d) Ventilation by thermal evacuation is sufficient if $10\text{ m}^3/\text{h}$ of exhaust air per kW of operating heat input are ventilated out of the installation room.

Ventilation by Mechanical Evacuation

- a) The products of combustion mixed with room air shall be evacuated from above the radiant heaters using fans.
- b) It shall only be possible to operate the radiant heaters when the exhaust air evacuation is assured.
- c) The number and arrangement of the fans depend on radiant heater arrangement and room geometry. The horizontal distance between a radiant heater and a fan shall not exceed six times the fan mounting height (measured to the axis of the fan) for wall mounted fans and three times the fan mounting height (measured to the axis of the fan) for roof mounted fans. The fans shall be installed above the radiant heaters, if possible near the ridge.
- d) Ventilation by mechanical evacuation is sufficient if $10\text{ m}^3/\text{h}$ of exhaust air per kW of operating heat input are ventilated out of the installation room.
- e) When applicable, the exhaust air flow rate shall take into account any exhaust air flow rate required for other purposes. The fan capacity is then computed based on the higher of these air flow rates.

Ventilation by Natural Air Change

Gas-fired radiant heaters may be operated without any special exhaust system if the exhaust gases are discharged to the outside atmosphere by a sufficient natural air change in the installation room.

No provision for thermal or mechanical ventilation is required in the following particular cases:

- Buildings with natural air change greater than 1.5 volumes per hour
- Buildings with a density of operating heat input not greater than $5\text{W}/\text{m}^3$

Air Supply

Air supply openings are required to admit air and shall be located below the radiant heaters.

Exceptions are possible if the air supply openings are between the individual heaters and their location has been planned after proper evaluation of the air flow.

The sum of the unobstructed cross-sections of all air supply openings shall not be smaller than the sum of the unobstructed cross-sections of all exhaust openings.

Slits and gaps of fixed cross-section can also be used as air supply openings.

Where the air supply openings can be closed, it shall only be possible to operate the radiant heaters when they are open.

Vented operation

In buildings having an air change rate of less than 0.5 per hour, additional natural or mechanical ventilation is required.

Natural ventilation: Ventilation openings with a free area of at least 2 cm² per kilowatt of rated heat input shall be provided.

Mechanical ventilation: Sufficient ventilation air shall be provided to ensure that the building air change rate is at least 0.5 per hour.

Note: When flued horizontally, the flue pipe must be arranged to provide a continuous rise from the appliance of 6mm per 1m length.

Note: The flue gas temperature downstream of the heater is at maximum 250 °C.

IMPORTANT		
	EUA 10, 20	EUA 30, 40, 50, 60
Maximum total exhaust vent length allowed for ø 100 mm	5 m	10 m
Maximum total fresh air inlet duct length allowed for ø 100 mm	5 m	8 m

Note: Subtract 1.5 m of allowable length for each 90° bend. Maximum of two 90° bends allowed.
- Install a minimum 500 mm straight length of duct for air intake or vent before any Tee or elbow.

Combustion Air Supply

- An outside combustion air supply is strongly recommended if the building space encloses a negative pressure due to exhaust etc. or if the building contains materials which would expose the heater to halogenated hydrocarbon atmospheres.
- The outside air terminal should be located at an elevation equal to or below the vent terminal elevation to prevent back-venting of flue gases into the burner compartment.
- If installing both an intake air and vent terminal through a sidewall there must be a minimum of 1 m separation, measured on vertical center line, between the intake air and vent terminations.

Supplying Fresh Air

Step 1

Remove the four nuts securing the Choke Plate to the Fan and remove it. Do not remove the gasket.

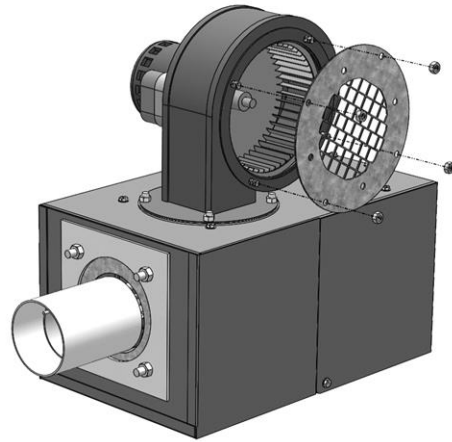

Step 2

Using four M6 x 12mm fasteners (not supplied), assemble the Choke Plate, Gasket, and Inlet Connector.

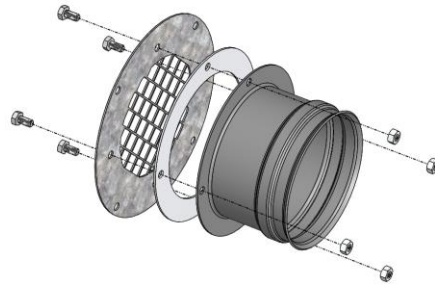

Step 3

Secure the assembly from the previous step to the Fan using four M6 nuts.

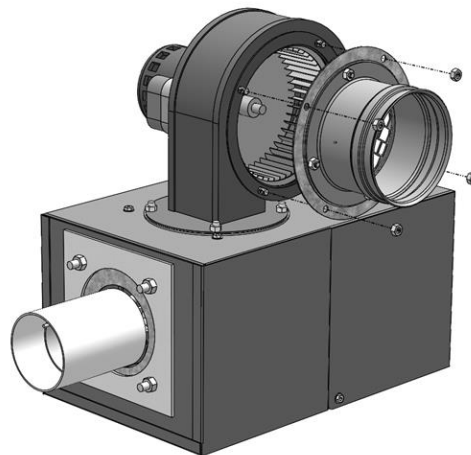

GAS SUPPLY

General Requirements

- Before connecting gas to the heater, check the supply gas and supply pressure: match the information on the rating plate of the heater.
- The gas meter and service must be sufficiently large to supply gas to the connected building gas load including the heating equipment and any other gas fired equipment. Additionally, the gas distribution piping must be designed according to National standards and Codes of Practice in the destination country. Generally, (low pressure) systems designed with a maximum 1.25 mbar (½" W.C.) total pressure drop meet this requirement.
- Gas supply pipe sizing must be in accordance with the National standards and Codes of Practice in the destination country. Minimum size to be 12.7 mm (½") bore.
- To accommodate the dynamic thermal expansion of radiant tube heaters, a flexible gas connection has to be realized. The flexible connection is achieved by the use of flexible gas hoses.
- Flexible gas hoses used for the installation of radiant tube heaters shall be of stainless steel construction. The minimum diameter of the hose shall not be less than the diameter of the inlet connection. The minimum length of the flexible hose shall not be less than 0.5 metres. The maximum length of the flexible hose including the fittings shall not be greater than 2 metres.
- Flexible gas hoses shall meet the requirements of EN 14800:2007. National standards and Codes of Practice in the destination country must be adhered to.

Flexible gas connectors of approved type must be installed as shown in Figure 10, in one plane, and without sharp bends, kinks or twists. A smooth loop of approximately 12" (300 mm) in diameter is best. Failure to install the gas connection in the approved manner will result in a hazardous and potentially deadly situation due to the movement of the heat exchanger and burner in the normal course of operation.

EUA 10, 20, 30, 40	12.7 mm (½") Flexible gas connectors	CG012
EUA 50, 60	19.1 mm (¾") Flexible gas connectors	CG024

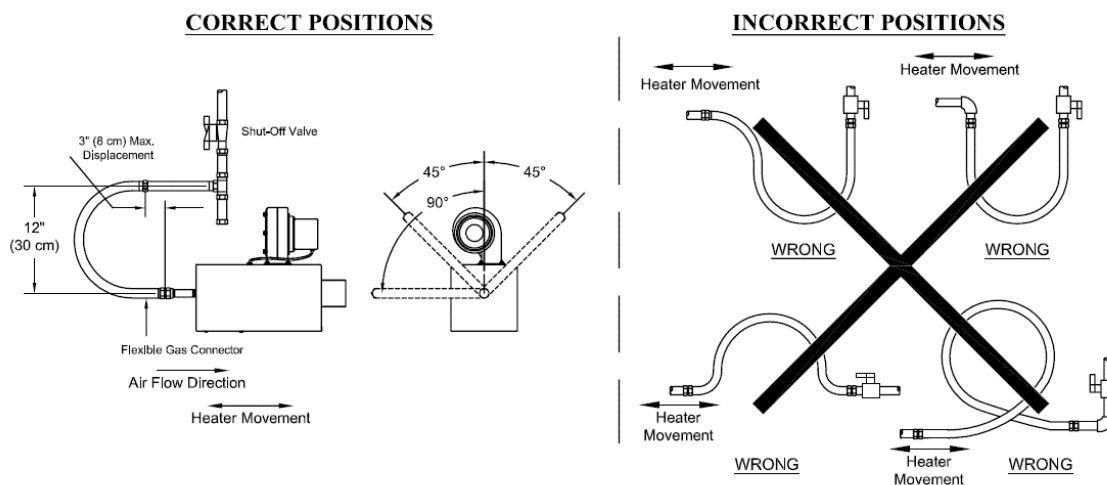

Figure 8: Flexible Gas Connections

ELECTRICAL WIRING

General Requirements

The electrical wiring to this heater must be installed in accordance with National standards and Codes of Practice in the destination country.

- Electrical supply 230V, 50Hz
- Power consumption 70W
- Current rating 0.3 A

Internal Wiring Diagram

This is a two stage heater.

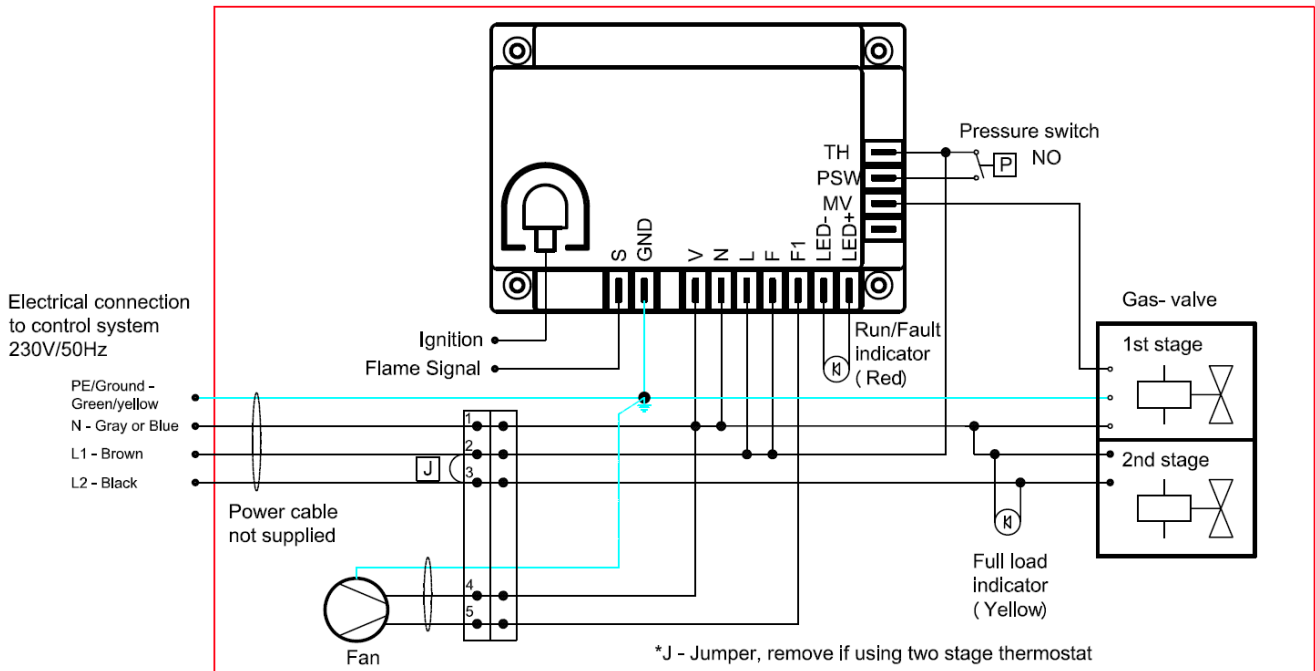
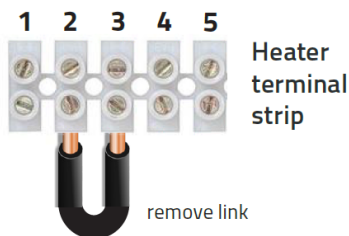

Figure 9: Wiring Diagram

Burner Terminal Connections

Before wiring commences, remove the link between terminals 2 & 3!



Wiring to each burner is as follows:
 The Earth stud requires an Earth feed
 Terminal 1 requires a Neutral feed
 Terminal 2 is a 230V feed for low fire
 Terminal 3 is a 230V feed for high fire
Terminals 4 & 5 are internal terminals only

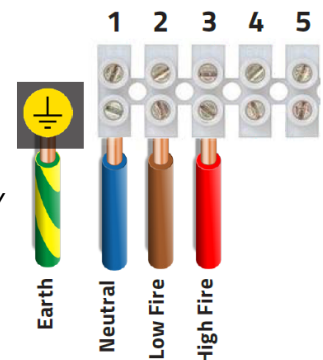

TYPICAL SCHEMATIC WIRING DIAGRAM

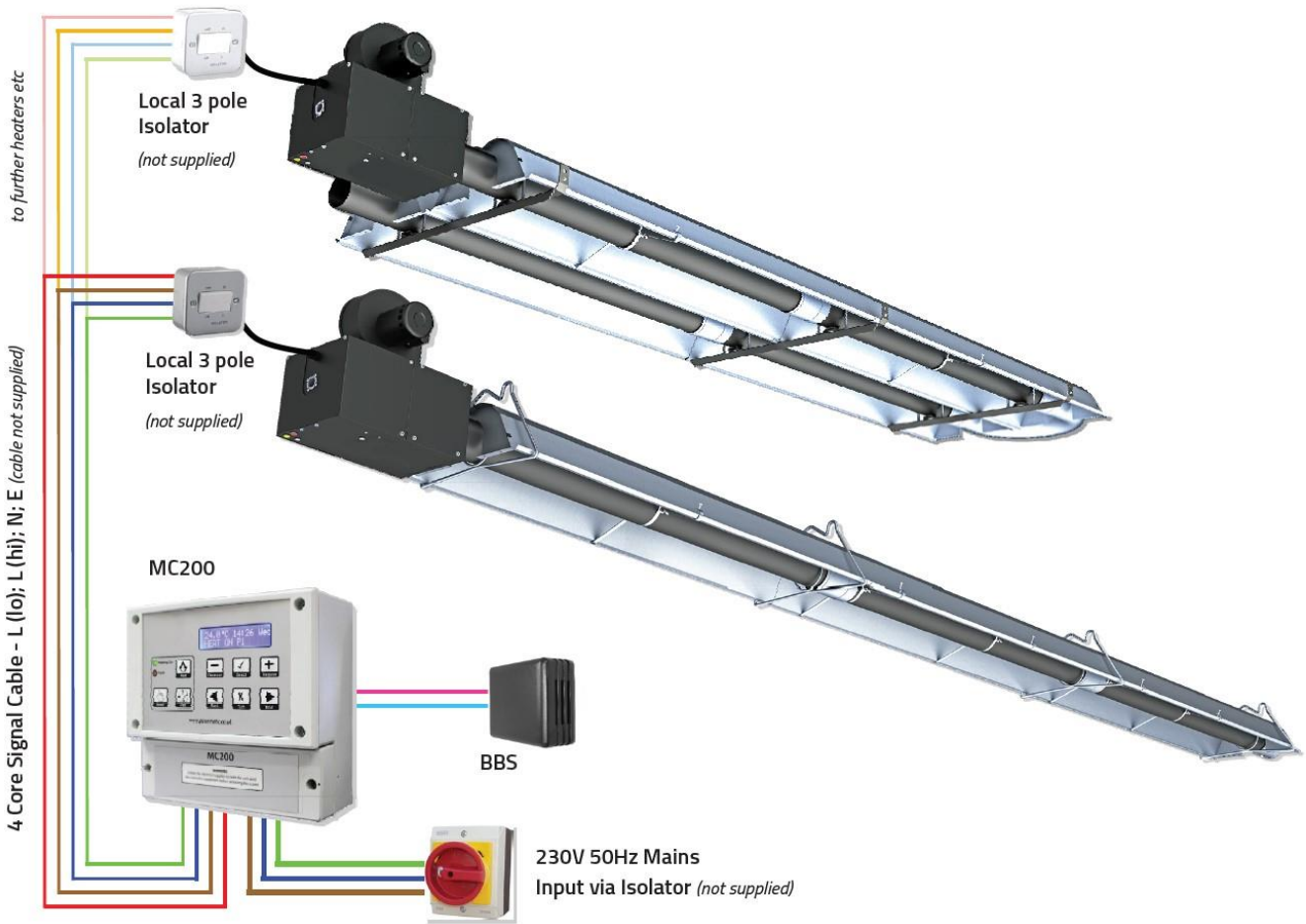

TYPICAL INTERCONNECTING WIRING DIAGRAM

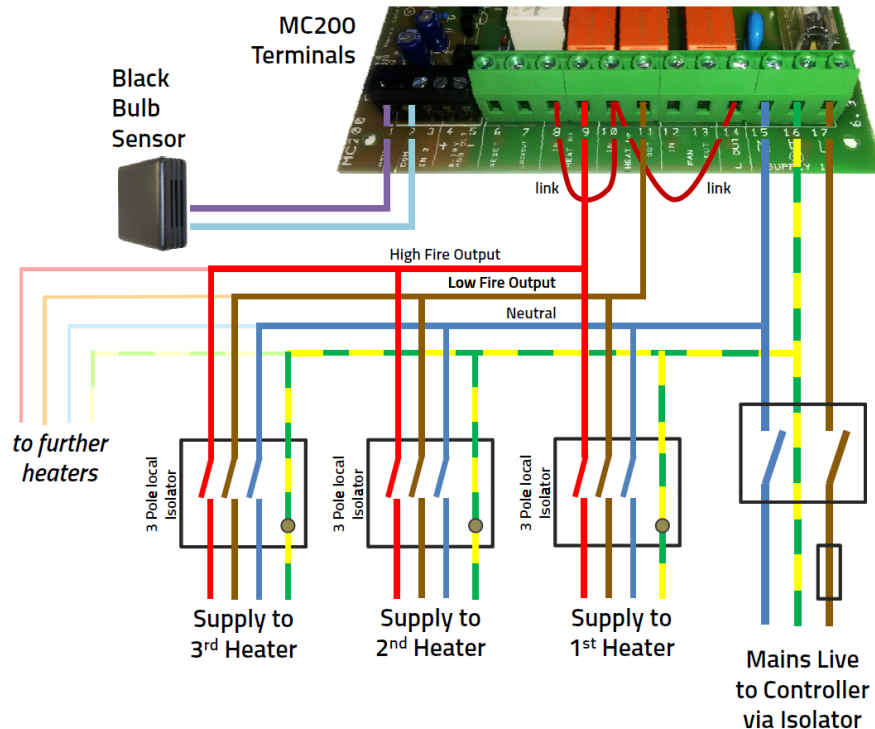

BURNER OPERATION

Air Pressure Switch

The heater is equipped with an air pressure switch located in the burner box. This device monitors the air pressure produced by the fan. In the event that the exhaust venting or the intake pipe becomes blocked or sufficiently restricted, the air pressure switch (normally open) will shut down the heater.

Starting sequence of operation

- Turn the thermostat on. When the thermostat calls for heat, the fan motor will energize.
- After fan establishes the flow, the air-proving switch closes and activates the ignition sequence.
- The ignition module, after a pre-purge period of approximately 45 seconds, energizes the igniter.
- The gas valve opens after sparking starts.
 - If a flame is detected within 7 sec, the ignition sensing rod "reads" a rectification signal and the gas valve remains open. The sparking stops when the flame signal is established.
 - If no flame is detected, the gas valve closes and a 30 seconds inter-purge period begins.
 - After the inter-purge, the module repeats the trial for ignition period.
 - If no flame is detected after three trials, the module will lockout.
 - Reset is accomplished by removing power from the module for at least 5 seconds.
- During normal operation the red pilot lamp is ON.
- The yellow lamp indicates that the heater is running at full load. At a partial load, the yellow lamp is OFF.
- To shut down the heater, switch off the electricity supply to the appliance. To shut down the heater for long periods of time, switch off the electricity supply and close the gas valve.

MAINTENANCE

For best performance, certain minimal maintenance procedures should be performed before each heating season. Installation environment and best practices should be considered in determining frequency.

- Before performing any services or maintenance, shut off gas and electrical supply to heater.
- Check condition of fan. Dirt and dust may be blown or vacuumed from the fan.
- Check condition of burner. Remove any foreign objects or debris from inside the burner box or burner cup.
- Inspect the igniter. Replace igniter if there is excessive wear or erosion, breakage, or other defects.
- Be sure the burner observation window is clean and free of cracks or holes. Clean or replace as necessary.
- Check the flue pipe for soot or dirt and reattach to the heater after cleaning as necessary.
- The reflector sections may be cleaned by wiping with a damp cloth.
- A service agency qualified to adjust and repair infrared heaters should be engaged for service other than routine maintenance.
- Be sure vent terminal and fresh air inlet are free from obstructions. If either pipe is restricted, the safety air switch will not operate properly, and the heater could fail to operate. Inspect any joints to make sure they are completely sealed.
- Check the inside of the radiant tubes visually with a flashlight. If carbon or scale are present, scrape or otherwise remove deposits (a wire brush works well).
- Check soundness of the heater suspension system.

Re-assemble the appliance in reverse order and commission in accordance with instructions.

ASSEMBLY INSTRUCTIONS SEQUENCE – EUA L

Step 1

The number of Hangers depends on the heater configuration; two to eight Hangers and Chains are required. All the chains must be aligned.

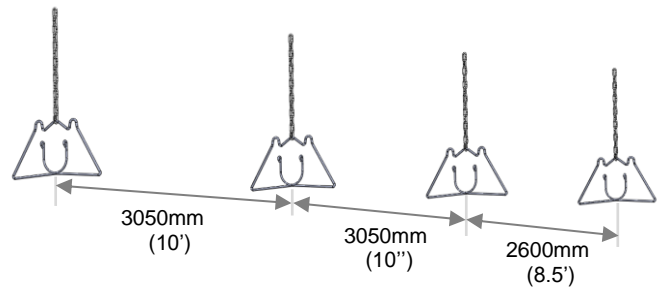

Step 2

Mount the Flanged Tube (**UT002**) on the Hanger (**CR003**) and ensure that the Tube's weld seam faces downwards.

Fasten Tube to Hanger using J-bolt and nut (required only for the first hanger, next to the flange).

Note: This applies also to inclined heaters.

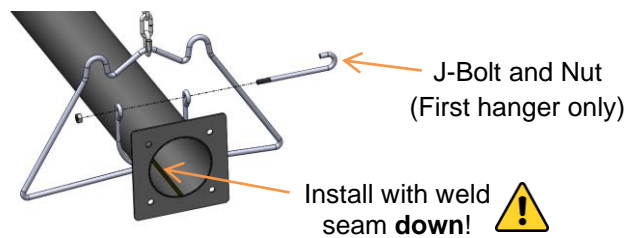

Step 3

The distance between the flange and the Hanger should be 150mm (6").

Slide Coupling on Tube (see next page for detail).

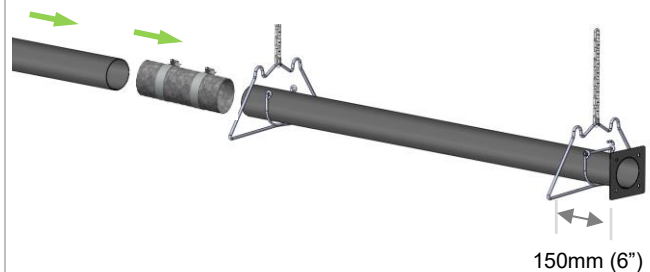

Step 4

Ensure that both Tubes hit the middle point of the Coupling to minimize gap between Tubes, as pictured.

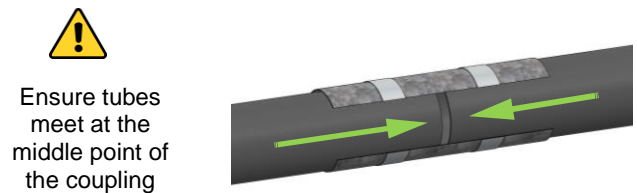

Step 5

Orient the Couplings to the 10 or 2 o'clock positions for nut accessibility. This also prevents interference with the reflector.

Torque nuts to 20 – 35Nm

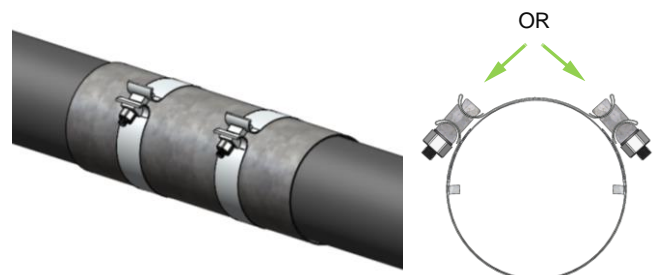

Step 6

Continue assembly by sliding Tubes through Hangers, and attaching all Couplings.

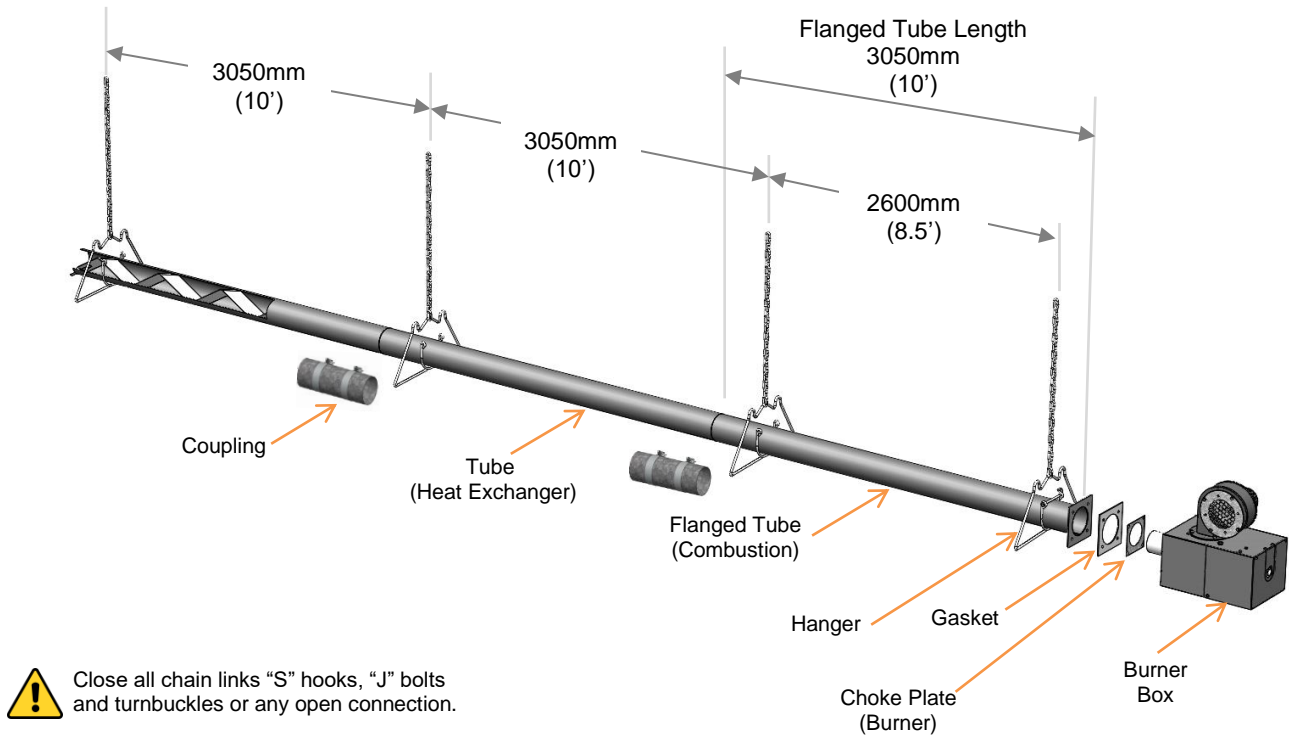

Step 7

If your heater's configuration has only one Turbulator, insert it into the Tube and skip to Step 10.

Line up the Turbulators at 90 degrees. Insert the tabs into the slot.

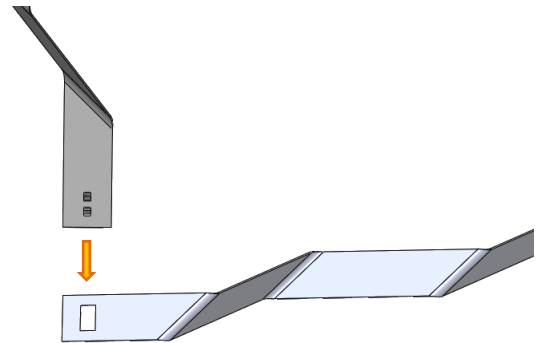

Step 8

Twist the Turbulators 90 degrees to lock them together.

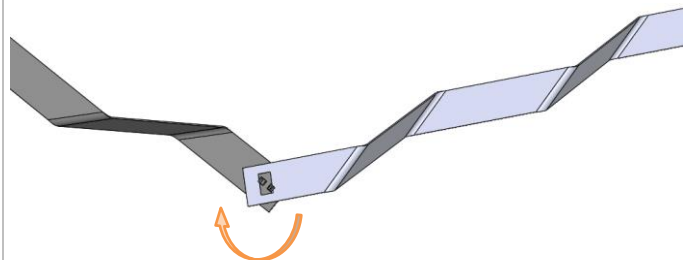

Step 9

Turbulators are ready to be inserted into the Tubes.

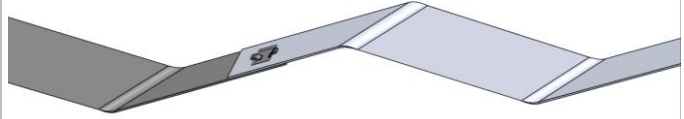

Step 10

Bend Turbulator Tab down, tightly over the edge of the Tube.



In linear systems, turbulators must be installed at the last section of the tube.

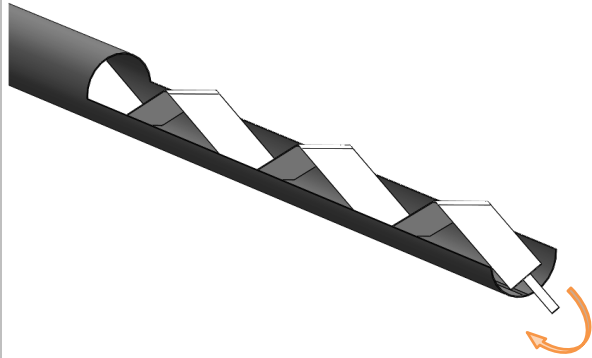

Step 11

Install the Burner Box onto the flanged Tube.

Refer to Packaging Contents page for part numbers and details.

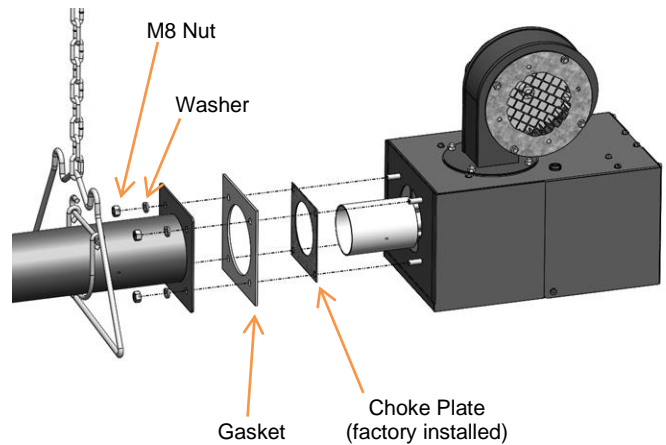

Step 12

Install the Reflectors by sliding them through the Hangers.

Refer to Step 13 and 14 to see how Reflectors should overlap in your configuration.

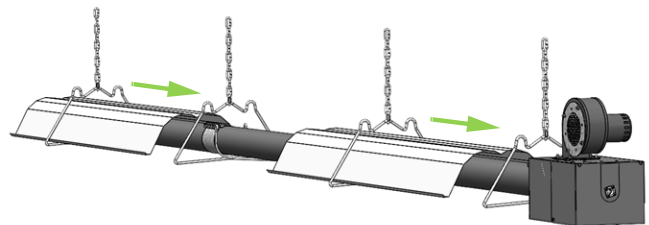

Step 13

Ensure Reflectors are installed as shown here and Step 14.



Incorrect overlap

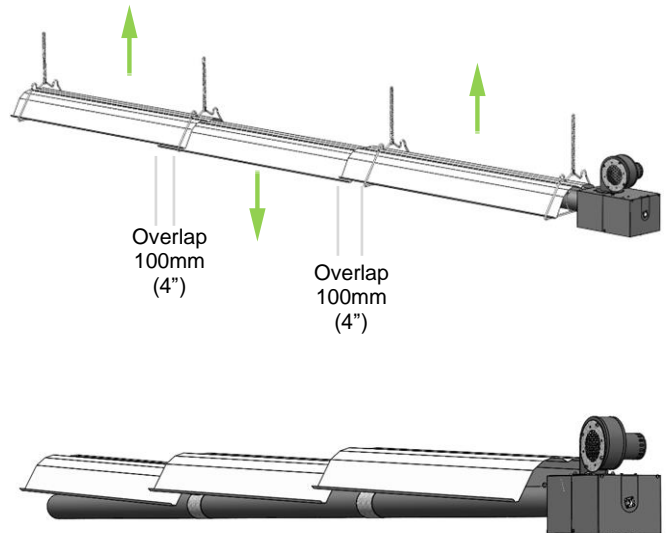

Step 14

Reflector overlap orientations:

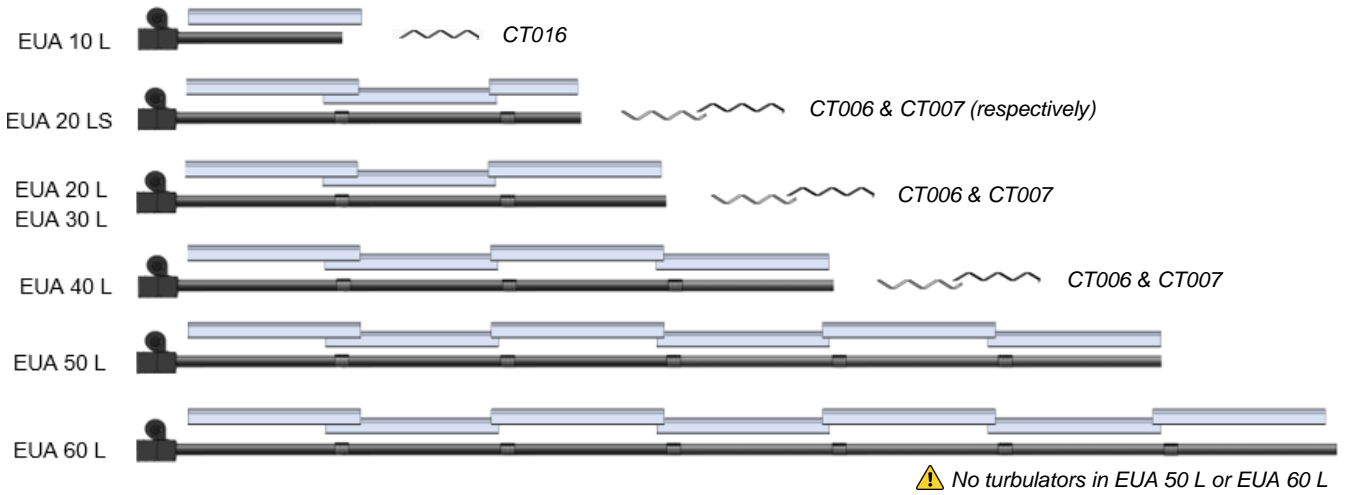

Step 15

Install the End Caps using U-clips.

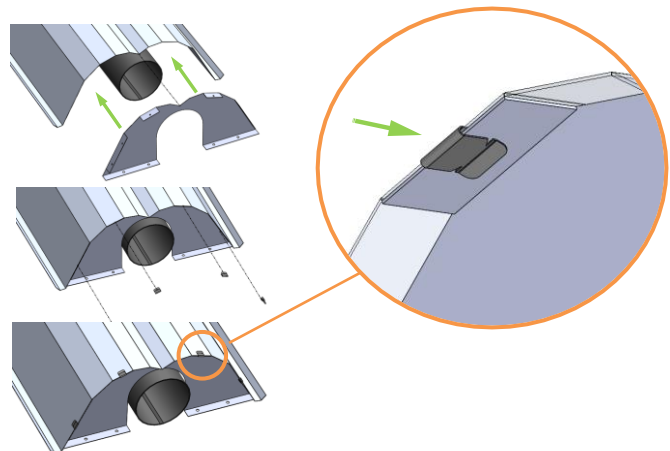

Step 16

Install Reflector Brackets (two parts that centralize the Tube within the Reflector).

Refer to the diagram below for Free and Locked orientations.

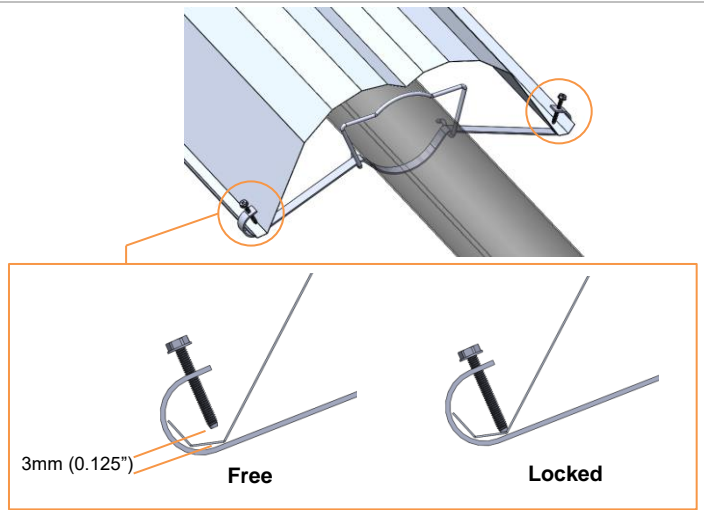

Step 17

Wherever the Reflectors are overlapping, the Bracket must lock them together, *except for the first overlap*.

Refer to the diagram below.

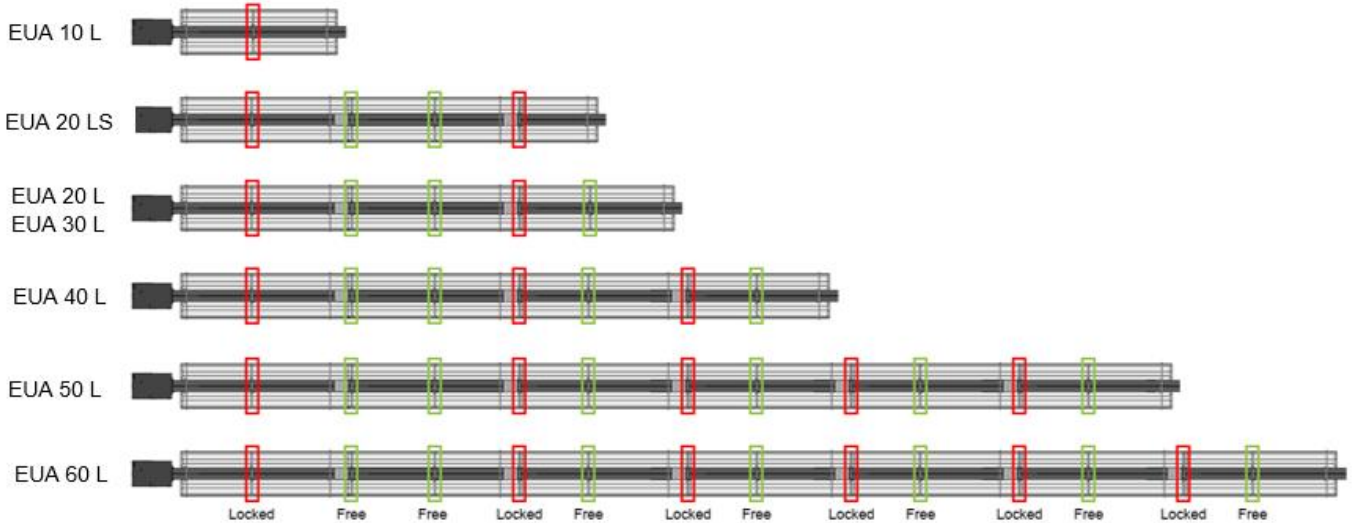
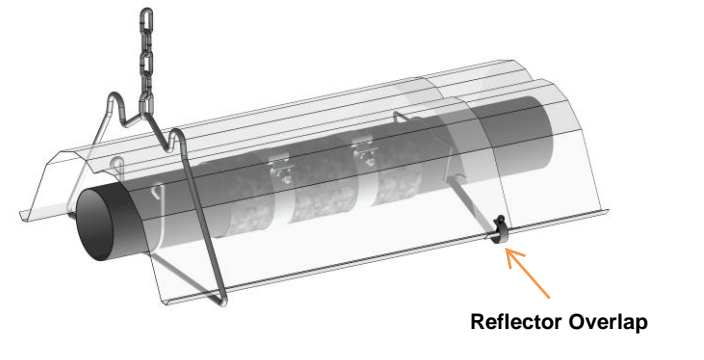

Completed Heater

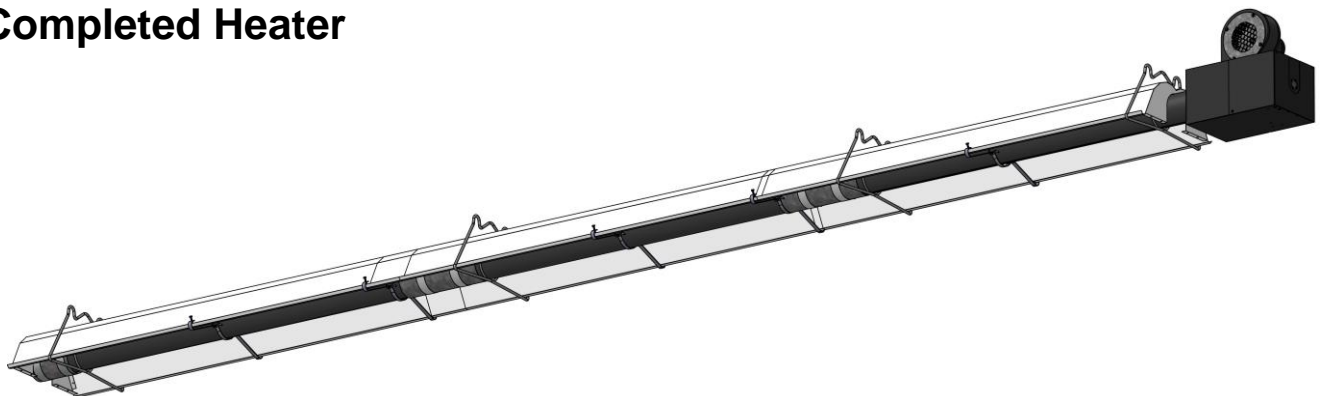

ASSEMBLY INSTRUCTIONS SEQUENCE – EUA U

Step 1

The number of Hangers depends on the heater configuration; two or three Hangers are required (consisting of a hanger kit and chains). All the chains must be aligned.

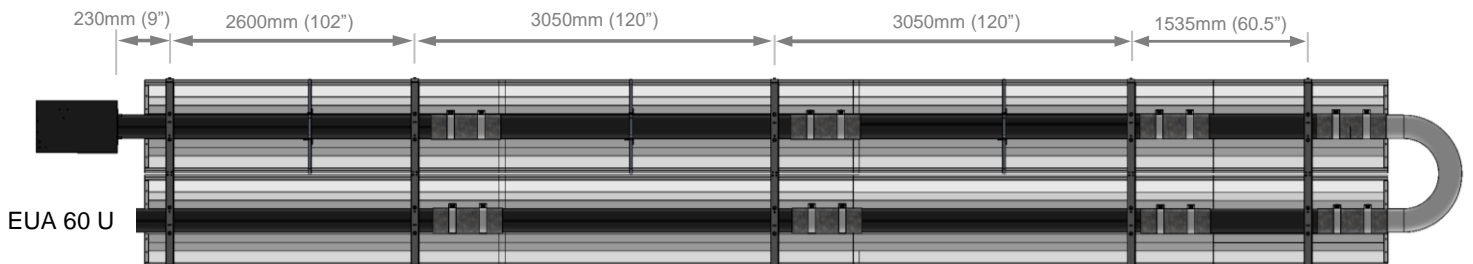
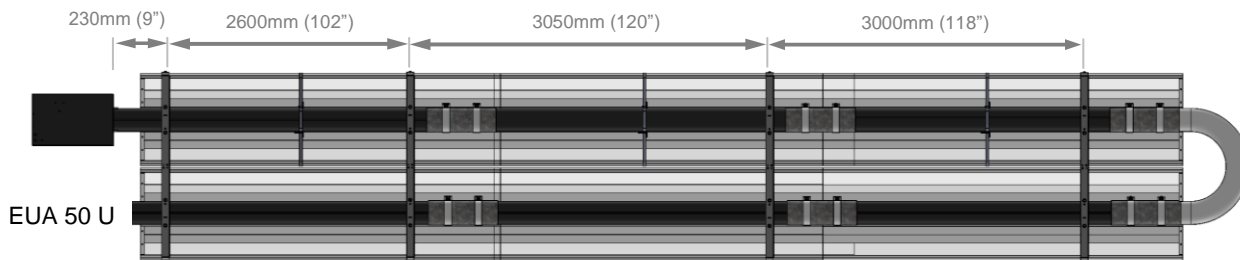
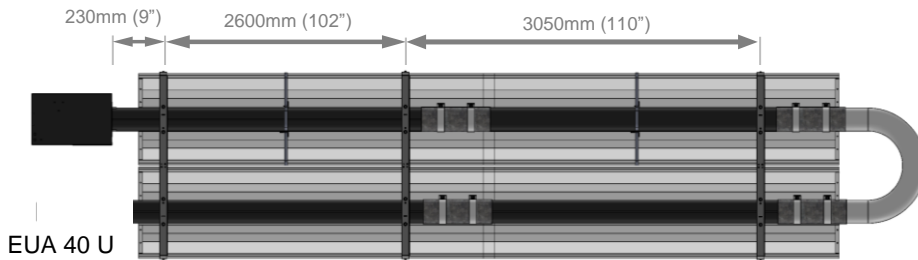
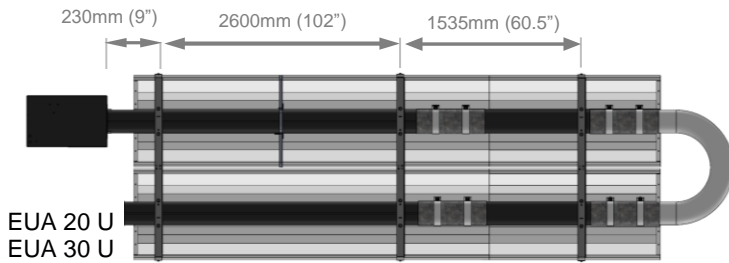
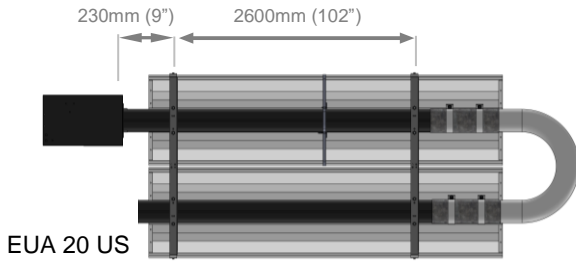

Step 2

Fasten the Tubes to the Hangers using the supplied U-bolts and nuts. **Refer to Step 3 for number of nuts required on each Hanger.** Ensure that the Tube's weld seam faces downwards.

Leave nuts finger tight until the end of assembly.

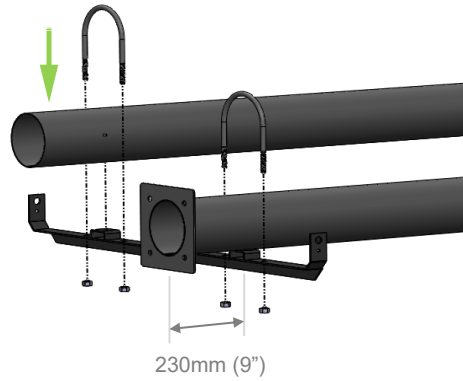

Step 3

Circled U-bolts require four nuts, otherwise use only two nuts per U-Bolt. 

Leave nuts finger-tight until end of the assembly.

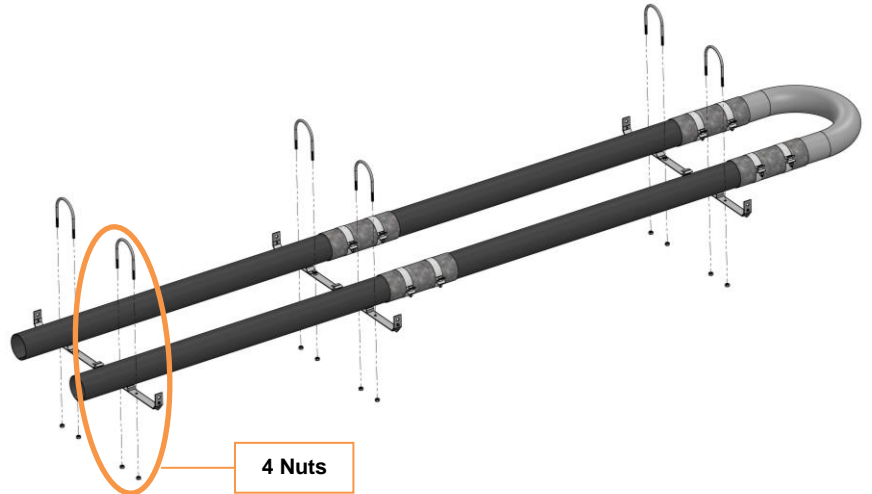

Step 4

Push the Tubes and U-Tube into couplings.

Don't tighten until orientation of Couplings is correct.



Step 5

Push Tubes as deep as possible to minimize gap.

Refer to next step for orientation of Couplings.

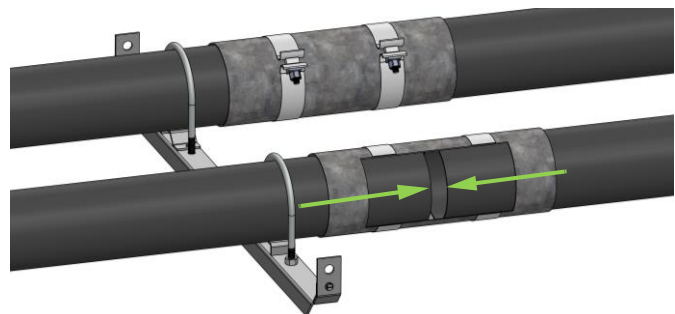

Step 6

Orient the Couplings to the 10 or 2 o'clock positions for nut accessibility. This will also prevent interference with the Reflector.

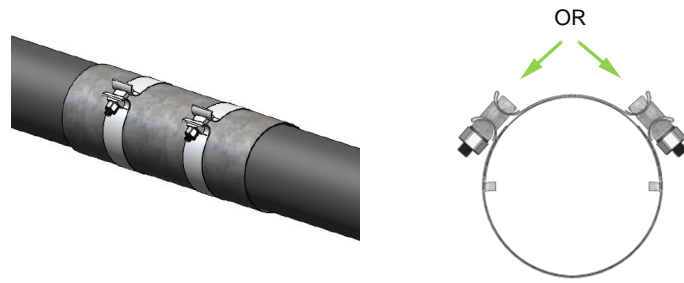

Torque nuts to 20 – 35Nm.

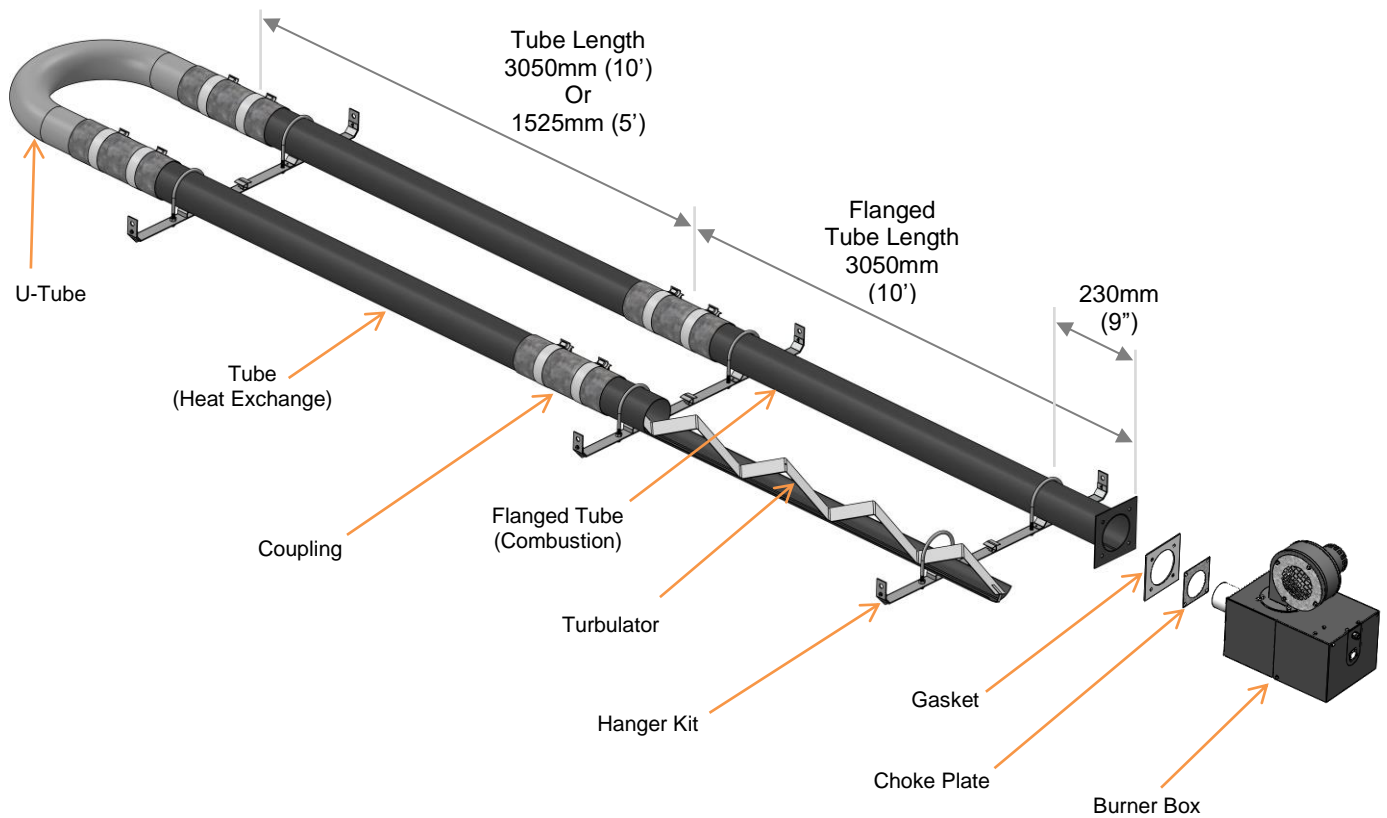

Step 7

Continue assembly by sliding Tubes through Hangers, and attaching all Couplings.

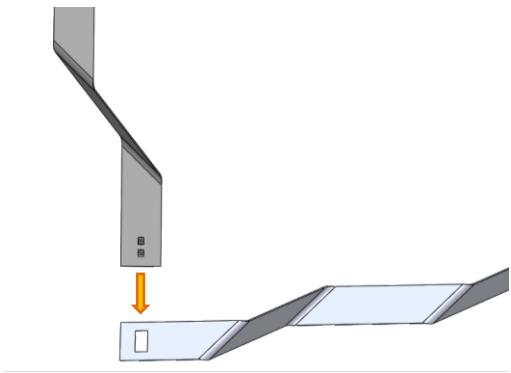
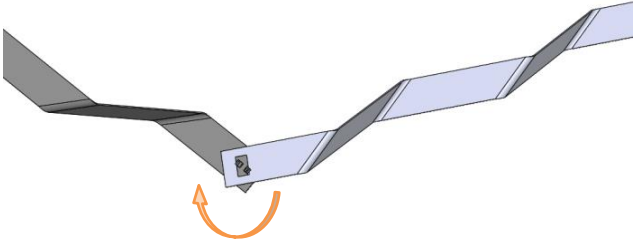
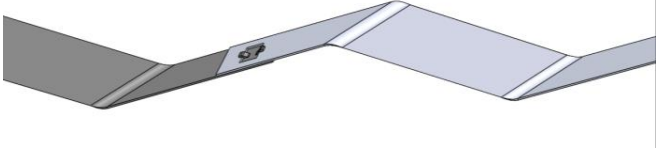

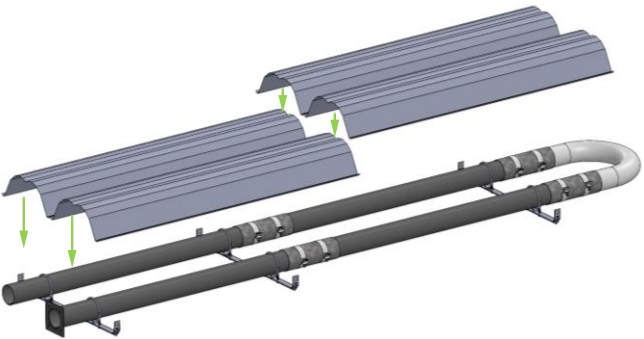
<p>Step 8</p> <p>If your heater's configuration has <u>only one</u> Turbulator, insert it into the Tube and skip to Step 11.</p> <p>Line up the Turbulators at 90 degrees. Insert the tabs into the slot.</p>	
<p>Step 9</p> <p>Twist the Turbulators 90 degrees to lock them together.</p>	
<p>Step 10</p> <p>Turbulators are ready to be inserted into the Tubes.</p>	
<p>Step 11</p> <p>Bend Turbulator Tab down, tightly over the edge of the Tube.</p>	
<p>Step 12</p> <p>The reflectors will overlap each other as pictured here.</p> <p>Refer to the next few steps for reflector installation instructions and sequence.</p>	

Step 13

Familiarize yourself with this Hanger Kit.

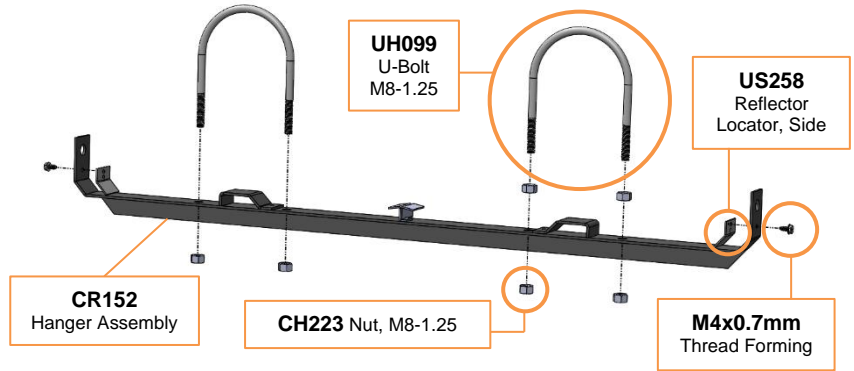

Step 14

Insert Reflector's edge flange under the Middle Reflector Locator (detail in next step).

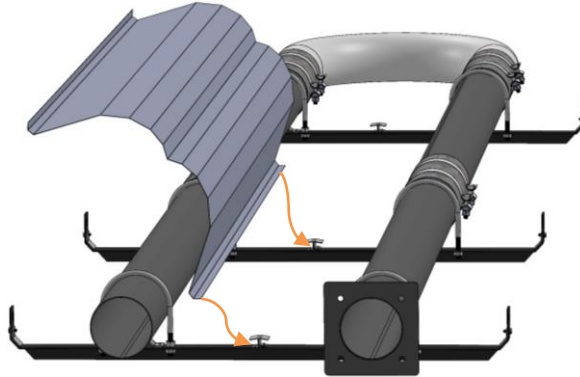

Step 15

Repeat the above step for the second Reflector.

Follow the same overlap sequence for the opposite side.

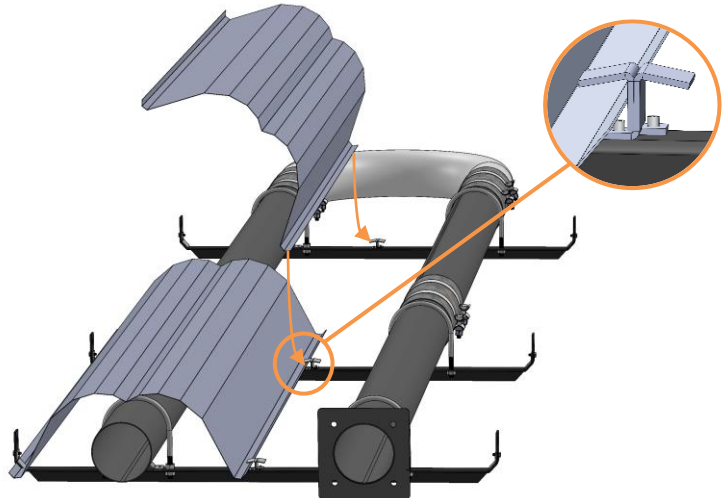

Step 16

Install Side Reflector Locators. Refer to next step for details.

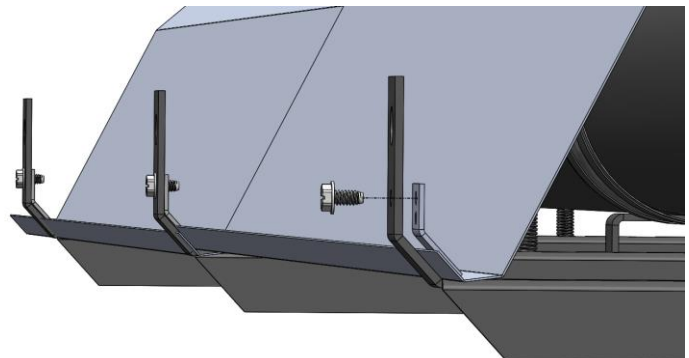

Step 17

Refer to the diagram showing Free and Locked positions for these Side Reflector Locators.

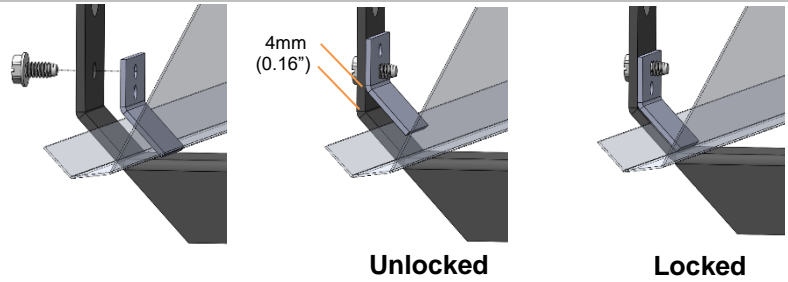

Step 18

Install Reflector Brackets (two pieces that centralize the tube within the reflector).

Refer to the diagram (next page) showing Free and Locked positions for these Reflector Brackets.

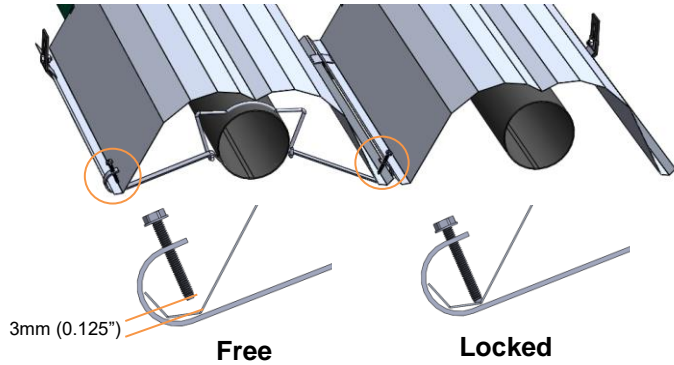

Step 19

Install end caps using U-clips.

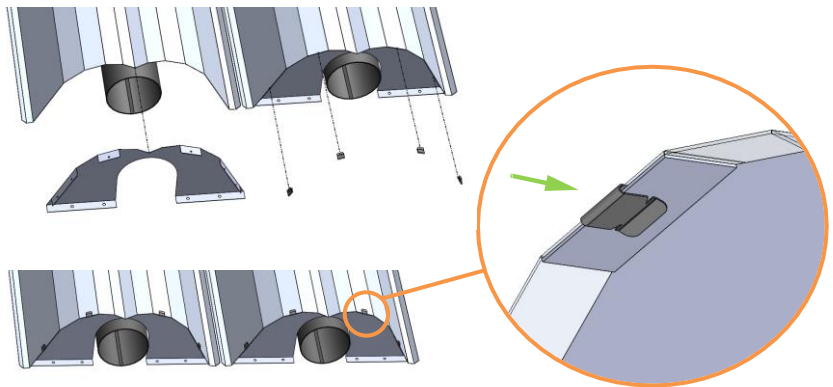

Step 20

Install the Burner Box onto the Flanged Tube.

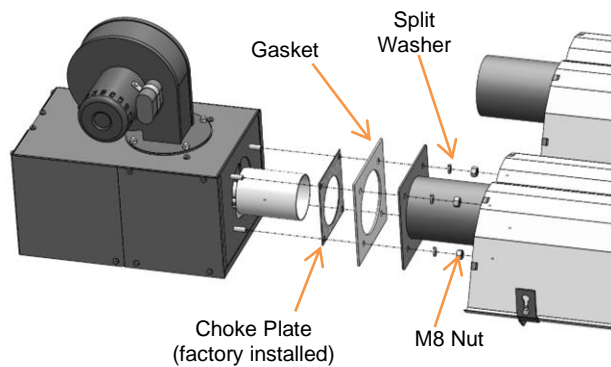

Completed Heater

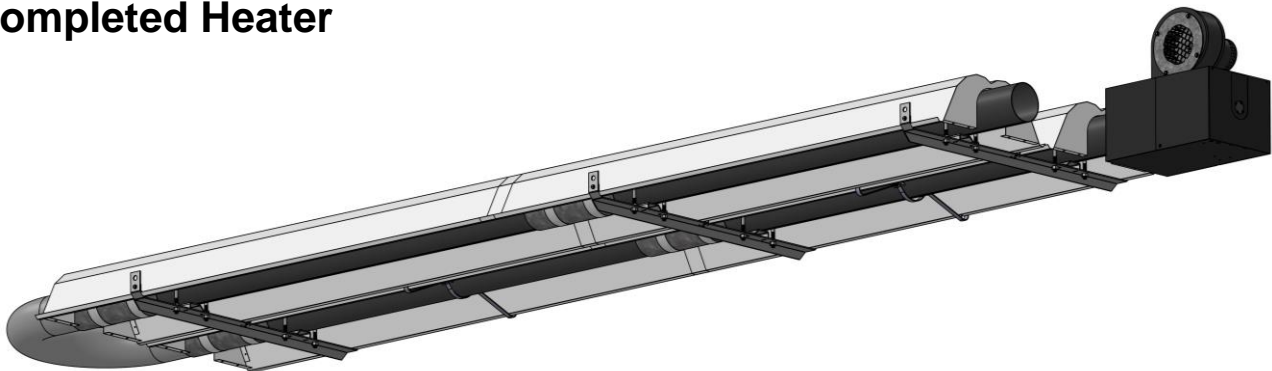

Reflector Overlap Detail

EUA 20 US



EUA 20 U EUA 30 U

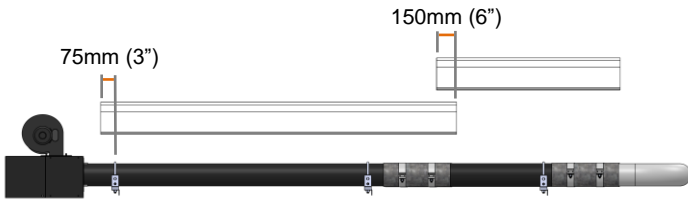

EUA 40 U

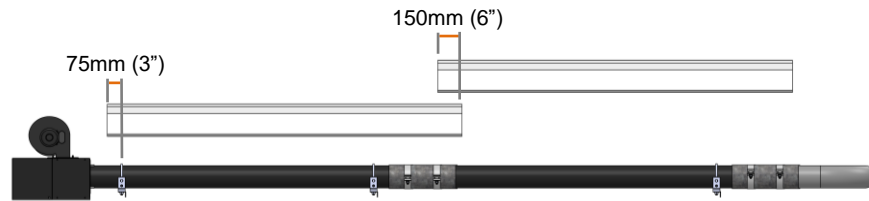

EUA 50 U

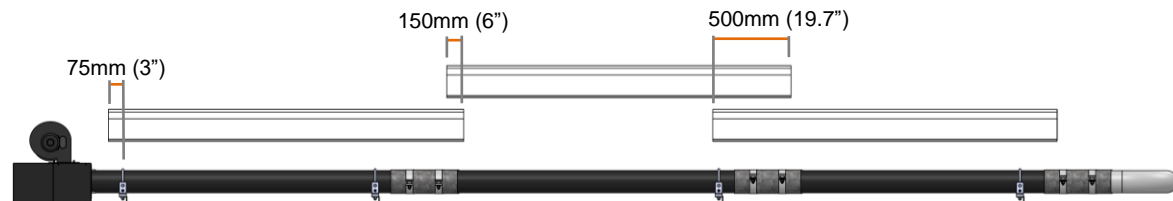

EUA 60 U

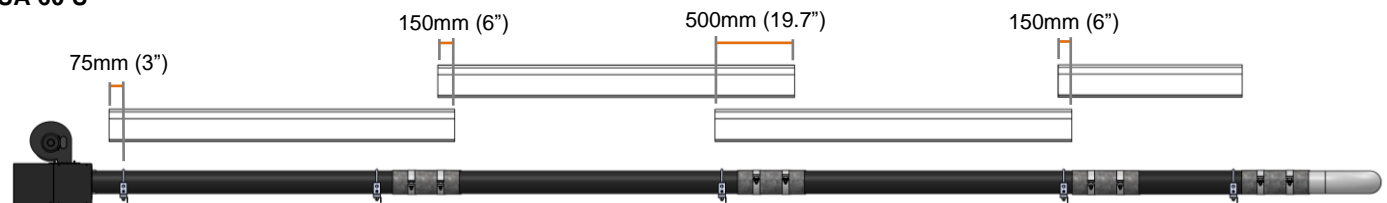

Turbulator Configuration Detail

EUA 20 US

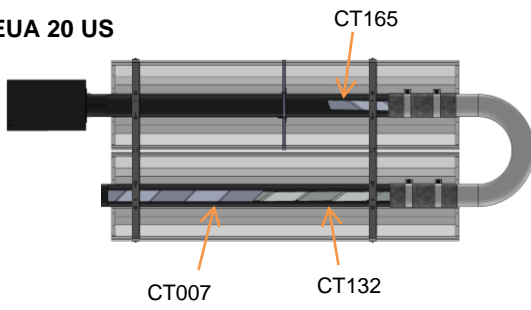

**EUA 20 U
EUA 30 U**

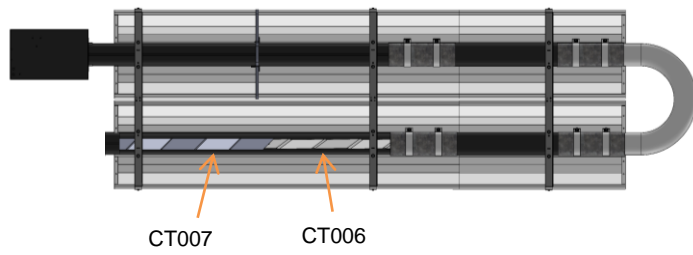

EUA 40 U

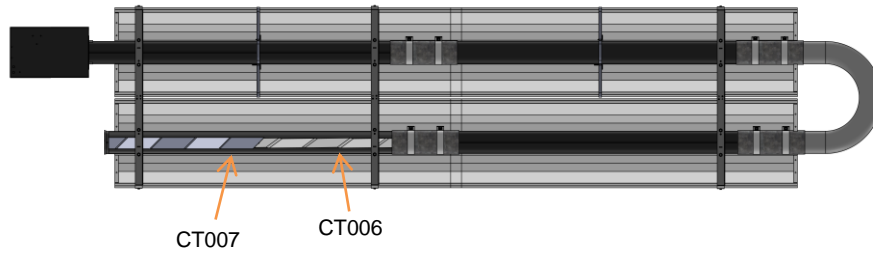

EUA 50 U

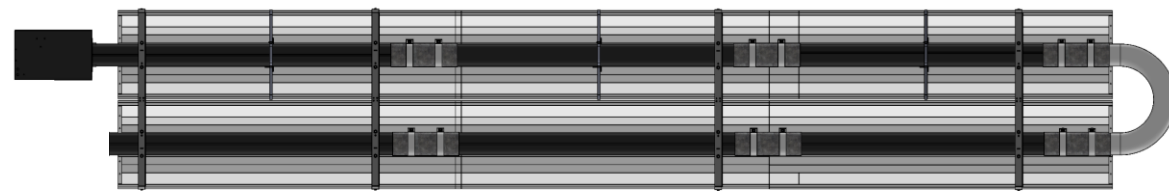

No Turbulators in models EUA 50 U and EUA 60 U

EUA 60 U

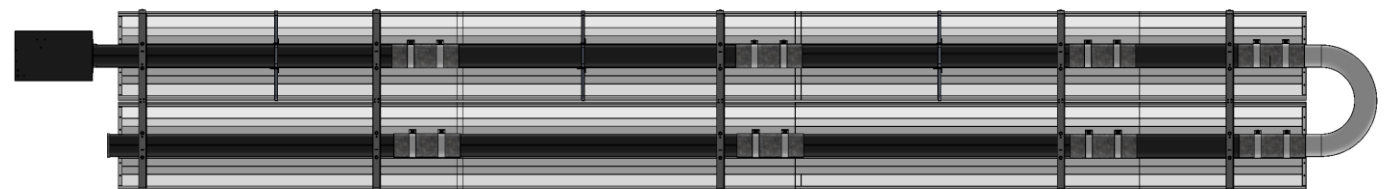

Hanger Configuration Detail

EUA 20 US

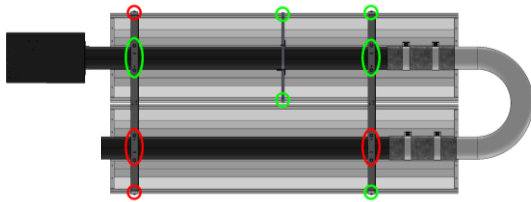

HANGERS:
O - LOCKED
O - FREE

EUA 20 U
EUA 30 U

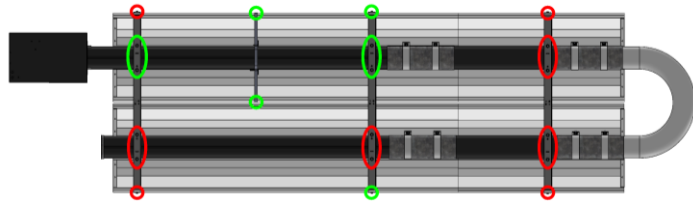

EUA 40 U

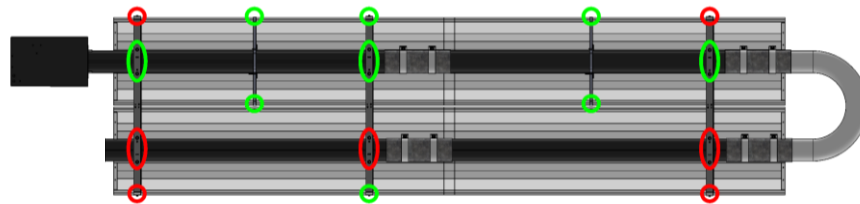

EUA 50 U

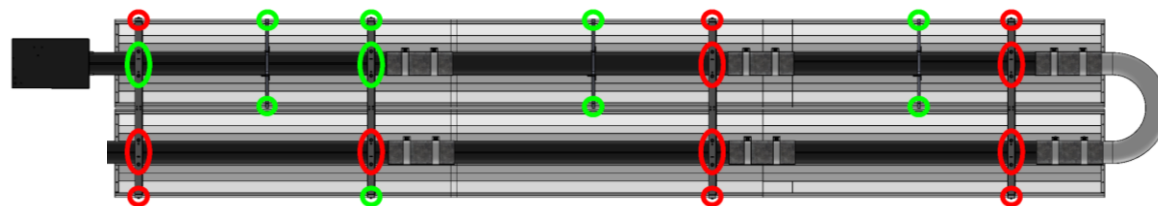

EUA 60 U

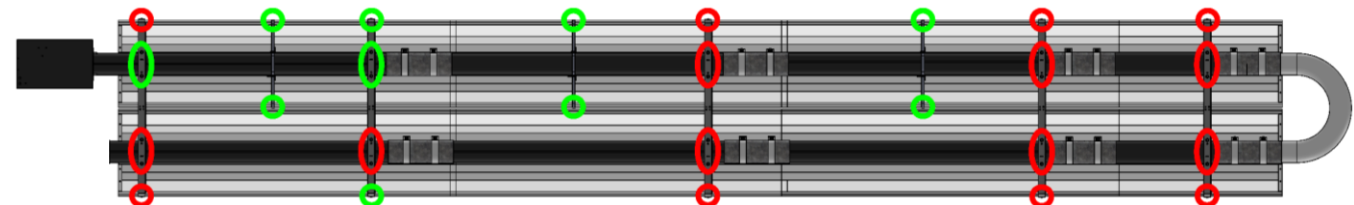

SIDE REFLECTORS

Step 1

Side Reflectors are 3150 mm (124") long. Fasten one Side Reflector per Reflector with M4 x 5mm screws (not supplied). Use three Side Reflector Brackets per Side Reflector. Space about 1220 mm (48") apart.

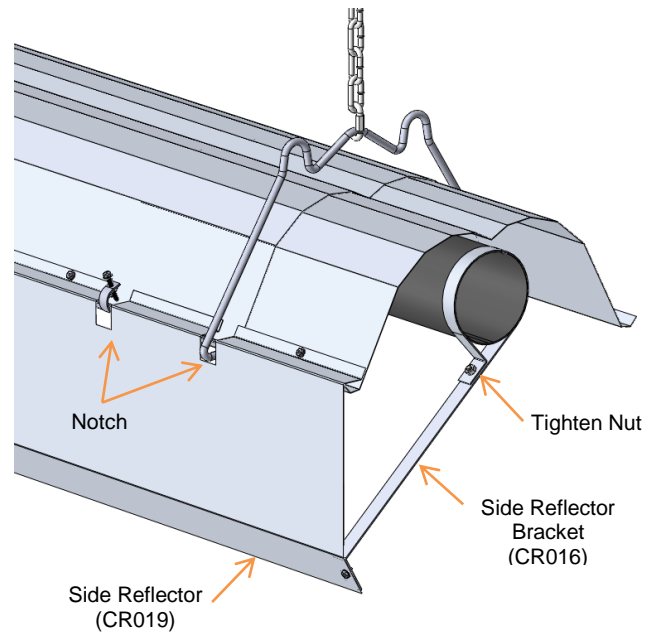

Step 2

Overlap Side Reflectors and then install Side Reflector Retainer Clip. See details below.

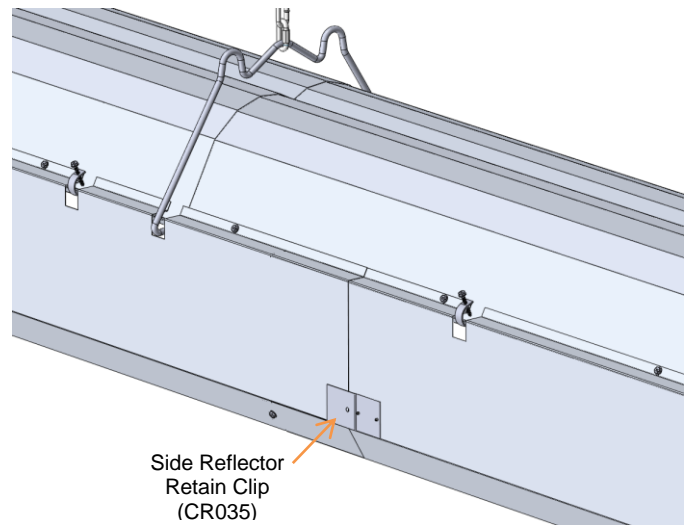

Step 3

Use the hole as a guide to position adjacent Side Reflector. The Side Reflector edge must be visible through the hole at room temperature. Screws to be installed from inside of Side Reflector. Install screws on one end of the Retainer Clip to allow movement.

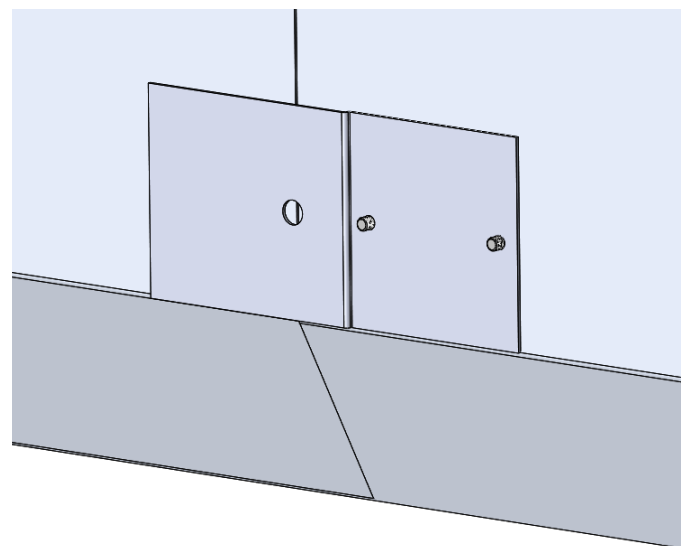

COMMISSIONING

Note: Use and complete this checklist before lighting the heater. Correct any conditions that do not meet these instructions.

Heater assembly

- Radiant tube weld seam facing down.
- Turbulators inserted at proper location. Turbulator tab bent over end of tube at 6 o'clock position.
- Tube couplings with the band clamp lock bolts oriented at the 10 o'clock or 2 o'clock position.
- Band clamps robustly tightened on the tube couplings.

Heater Location

- Located indoors.
- Installation area free of corrosive elements and flammable material.
- Proper clearances from combustibile surfaces maintained.
- Sufficient room to service the heater.
- Requirements for combustion air supply and dilution air for unvented heater.
- Heater installed with a slope downward and away from the burner of 6mm in 3 m.
- All Quick links are tightened up / S-hooks closed.

Gas Supply and Piping

- Gas supply and gas type are as specified on the heater label.
- Gas line equipped with shut-off valve, union and sediment trap.
- Approved pipe joint compound used.
- Adequate pipe size and of approved material.
- Check all connections and fittings for possible gas leaks.

Vent Pipe System

- Approved size, length and number of elbows on exhaust vent and air intake system.
- Installed in accordance with prevailing provisions of local codes.
- Horizontal piping slopes at an upward pitch of 6 mm rise per 3 m away from the heater.
- Free of obstructions.
- General rules for vent terminals
- Away from corners, other vents, windows etc.
- Exhaust and Air Intake terminations 450 mm minimum above roof/snow level.
- Check the operation and interlocking of extract and fresh air supply fans, where appropriate.

Electrical Connections

- Heater properly grounded.
- Check electrical earth continuity between the heater, gas pipework and mains electricity supply.
- Installed in accordance with prevailing provisions of local codes.
- Check to ensure that the electrical components are of the correct voltage range.
- Check for correct connection and operation of all external components, e.g. thermostats and time switches.

After all actions on checklist are checked / completed, **proceed with start-up.**

TROUBLESHOOTING

The burner has two display lamps, a yellow one and a red one.

- The yellow lamp indicates that the heater is running at full load. At partial load the yellow lamp is OFF.
- The red lamp indicates:
 - Burner is operating when red lamp is ON.
 - Control Module Error Codes:
 - 1 FLASH – Airflow fault
 - 2 FLASHES – Flame – No call for heat
 - 3 FLASHES – Ignition Lockout
 - 4 FLASHES – Control Fault

Fan / Motor Fails To Run

- Is the thermostat calling for heat? Is there 230 V electrical supply?
- Check fan for obstructions. Replace fan if necessary.
- Air Pressure Switch (N.O.) Failed Closed. Replace as necessary.

The Ignition Module Fails to Energize the Igniter

- Check air pressure switch performance with a manometer – Compare with switch setting.
- Ensure the correct size of exhaust and air intake pipes were used per the instruction manual for vent length. Ensure maximum number of elbows or equivalent feet of both pipes was not exceeded. Ensure there are no obstructions in the exhaust and air intake pipes.
- If the air pressure switch performance test results prove the air pressure switch is working properly, and all other steps are followed, and fault code persists – replace the control module.

No Gas Supply

- Check to see if manual supply valve to heater is ON (Open). No manifold pressure indicates valve is closed. Gas pressure downstream of gas valve can be measured by connecting a manometer to pressure tap on gas valve.
- Supply gas pressure can be checked at pressure tap in gas supply system.

Burner Does Not Light

- Is spark evident during ignition trial? If no, further electrical checks are required.
- Check to see if gas lines were properly purged of air.
- Check inlet and manifold gas pressure during ignition period.

Burner Does Not Stay Lit

- Check ground wire continuity.
- Check insulation on the igniter leads.
- Measure flame signal current: minimum 0.8 micro amps.
- Clean flame rod if necessary.
- Replace control module if necessary.

Troubleshooting Chart

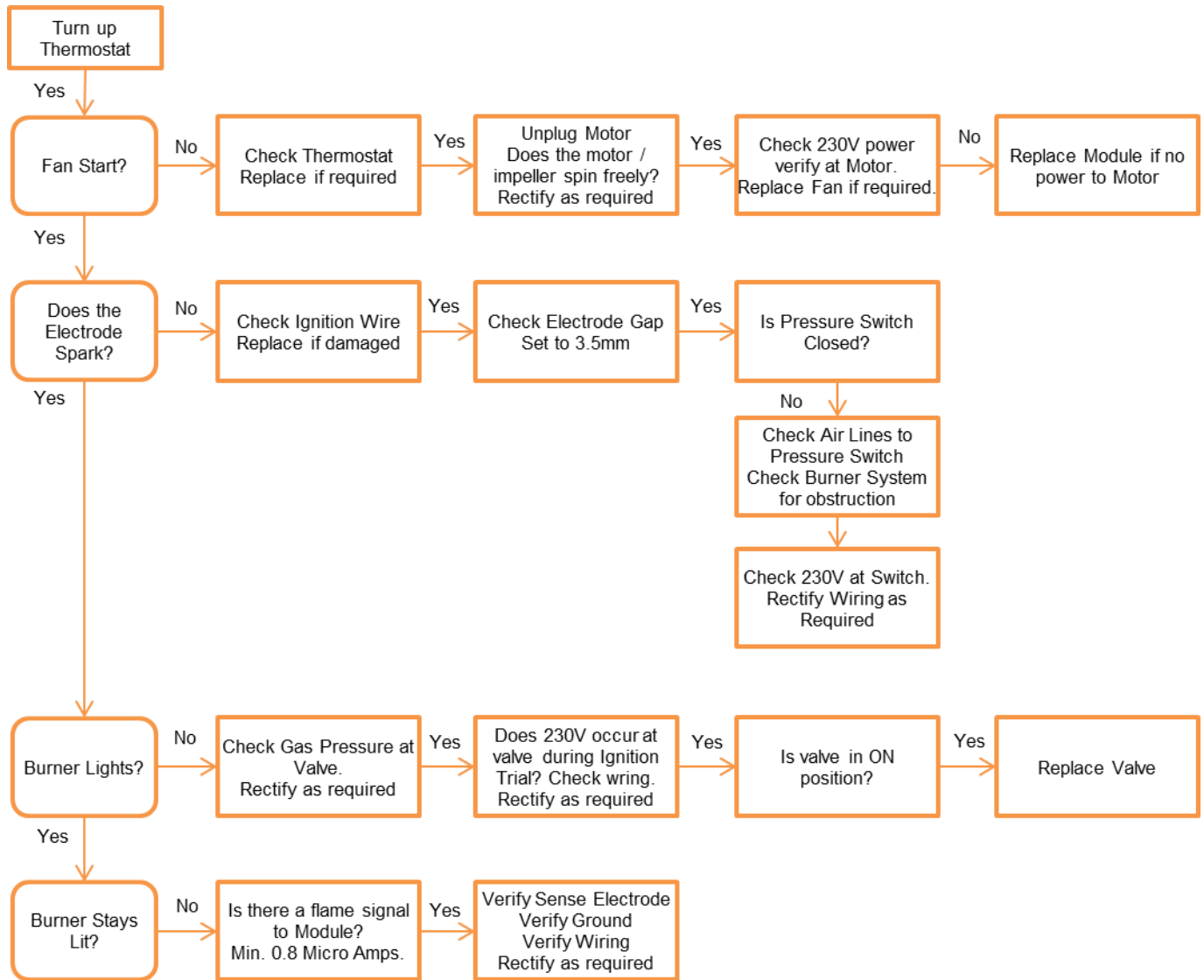

CONVERSION INSTRUCTIONS

Adjusting the manifold pressure

Check inlet and outlet pressure using the pressure test points provided. After testing, carefully seal test points with the provided screw.

- Remove the modulator plastic cap E
- Full load pressure: energize the modulator. Screw the nut C clockwise to increase the manifold pressure and screw it counter clockwise to decrease manifold pressure.
- Partial load pressure: cut-off the power supply to the modulator and, keeping the nut C blocked, screw in the screw D to increase the pressure and screw it out to decrease it. Use screw driver 6x1 blade.
- Put back the modulator plastic cap.

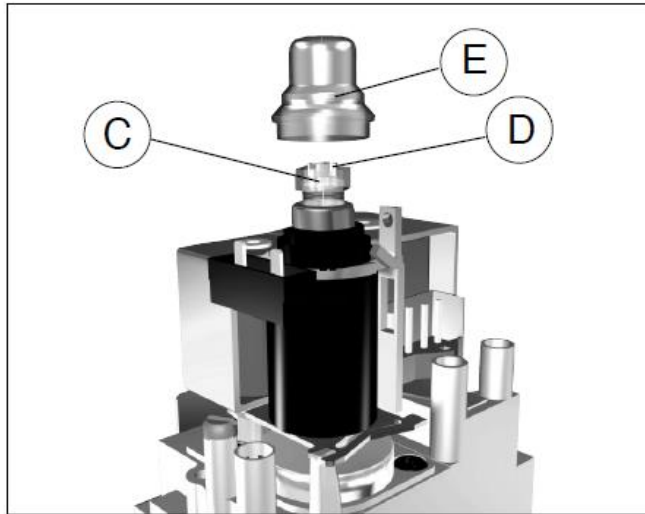

Figure 10: Modulator

- Ensure that the flame does not go out and light back does not occur at the full and partial load gas manifold pressure.

Conversion from Natural Gas to Propane

- Remove the injector and replace it with the alternative injector supplied with conversion kit. Check that the size reference marked on the injector agrees with that listed in the Specifications table for the heater model.
- Adjust the manifold pressure, check supply and manifold pressure in accordance with specs.
- Affix the gas adjustment label (Propane 37mbar) supplied with conversion kit onto the rating Plate, adjacent to the headings "Adjusted For" and "Setting Pressure", to cover the original gas adjustment label (Natural Gas, 20mbar).

Conversion from Propane to Natural Gas

- Remove the injector and replace it with the alternative injector supplied with conversion kit. Check that the size reference marked on the injector agrees with that listed in the Specifications table for the heater model.
- Adjust the manifold pressure, check supply and manifold pressure in accordance with specs.
- Affix the gas adjustment label (Natural Gas, 20mbar) supplied with conversion kit onto the Data Label adjacent to the headings, "Adjusted For" and "Setting Pressure" to cover the original gas adjustment label (Propane, 37mbar).

REPLACEMENT PARTS

ITEM	Part No.	DESCRIPTION
1	RP-UE015	Indicator Light (Yellow)
2	RP-UE014	Indicator Light (Red)
3	RP-CE299	Ignition Module
4	RP-CG324	Gas Valve
5	RP-CE301	Fan Assembly
6	RP-CE003	Flame Sensor Electrode
7	RP-CE002	Spark Electrode
8	RP-UG001P	Burner Cup
9	RP-CE316	Air Switch EUA 10
	RP-CE316	Air Switch EUA 20
	RP-CE317	Air Switch EUA 30
	RP-CE321	Air Switch EUA 40
	RP-CE316	Air Switch EUA 50
	RP-CE449	Air Switch EUA 60

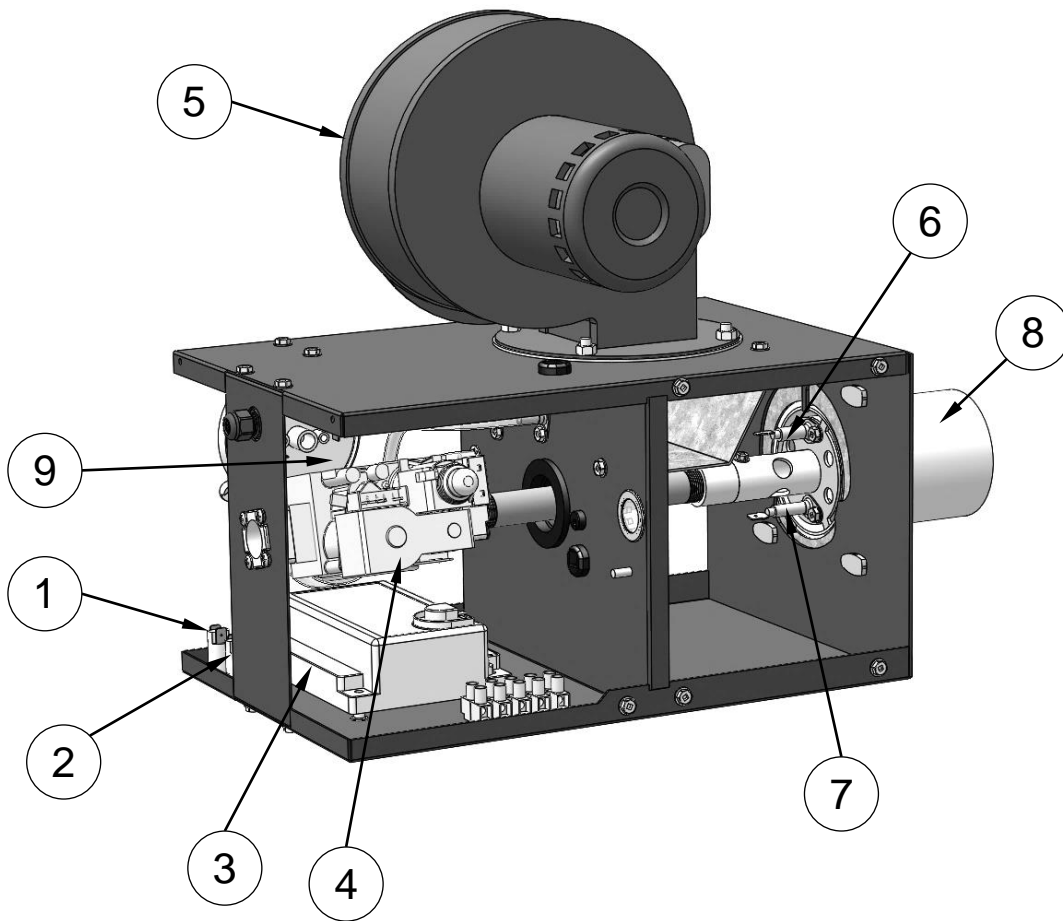

Figure 11: Burner Box Replacement Parts

REPLACING PARTS

⚠ WARNING

ELECTRIC SHOCK & EXPLOSION HAZARD

Disconnect electrical power and gas supply before servicing. Failure to do so may result in death or serious injury.

Removal of Service Door and Combustion Door

1. Remove the two screws (A) to swing open the Service Doors.
2. Remove the four screws (B) to access the Combustion Chamber.

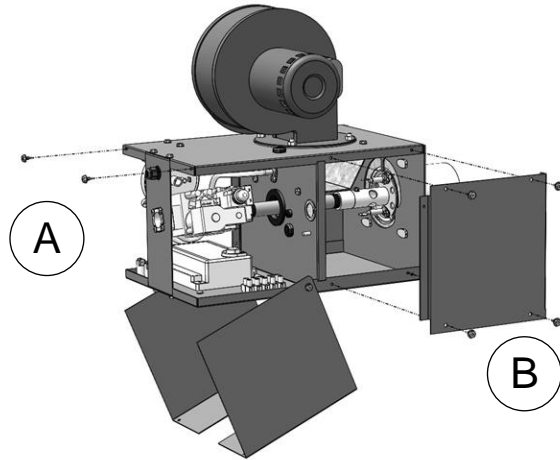

Removal of Burner Cup and Injector

1. Remove the screw and slide the Burner Cup Assembly off of the Injector Holder.
2. Use a 1/2 inch (12.7mm) spanner to loosen and remove the Injector.



See Burner Cup replacement instructions below.

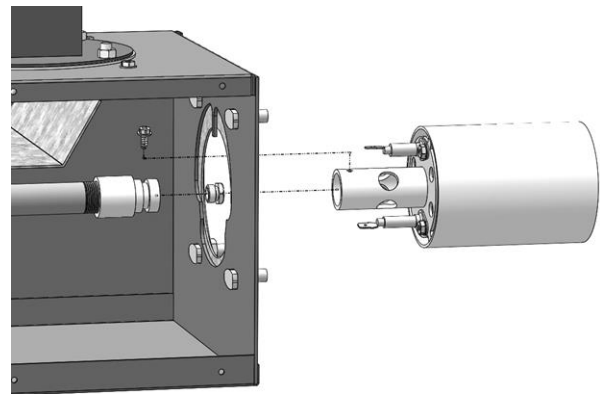

Removal of Spark Electrode and Flame Sense Electrode

1. To remove the Flame Sense Electrode (A), remove the screw and pull straight out.
2. To remove the Spark Electrode (B), remove the screw. Pull and twist to maneuver the bend in the electrode out of the hole.



When replacing Burner Cup make sure Flame Sense Electrode (A) is oriented in the 12 o'clock position.

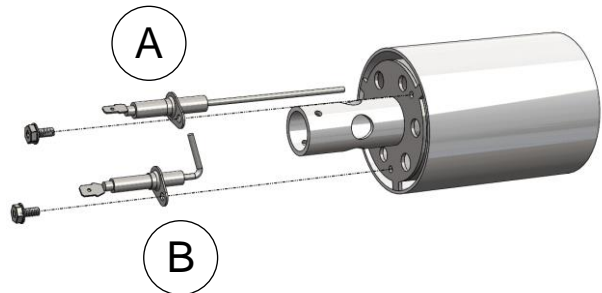

Removal of Module

1. Disconnect all the wires.
2. Remove the two screws and nuts and remove the module from the Burner Box.

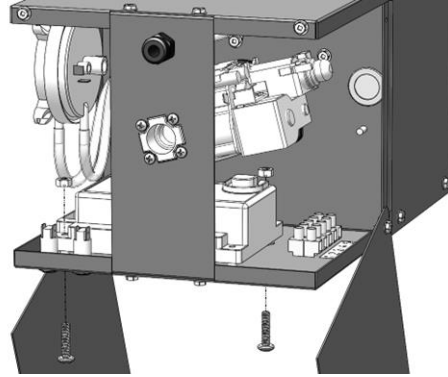

Removal of Air Switch

1. Disconnect the two clear hoses from the air switch and the two electrical connectors.
2. Remove the two screws from the Top Pan.
3. If removing the air switch from the bracket, remove the two screws that mount the air switch to the bracket.

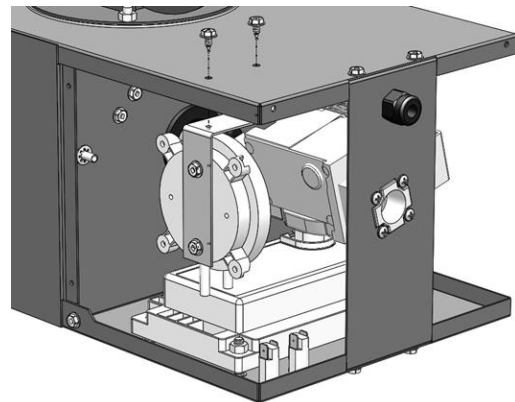

Removal of Gas Valve and Manifold

1. Remove the four screws (A) from the Top and Bottom of the Burner Box.
2. Remove the four screws (B) from the Valve Support Plate.
3. Use a pair of pliers to pull the Grommet out of the hole.
4. Unscrew the Nipple from the Gas Valve.

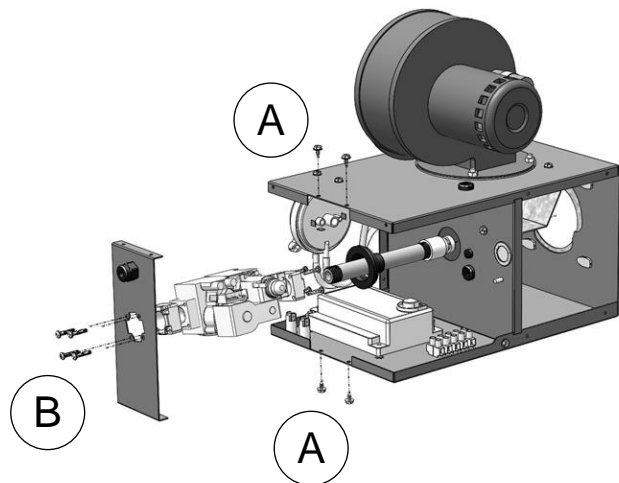

Removal of Indicator Lights

1. Disconnect the wires from the Indicator Lights.
2. Press the tabs on either side the Indicator Light and remove from Burner Box.

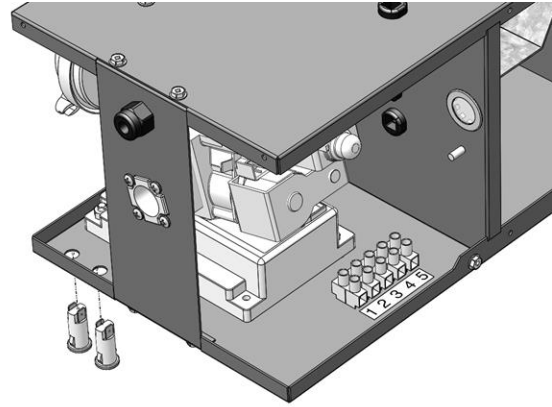

Removal of Fan

1. Disconnect wires.
2. Remove the four M6 nuts (A) that secure the Fan Assembly to the Burner Box.
3. Remove the four M6 nuts (B) that secure the Choke Plate and Gasket to the Fan Assembly.

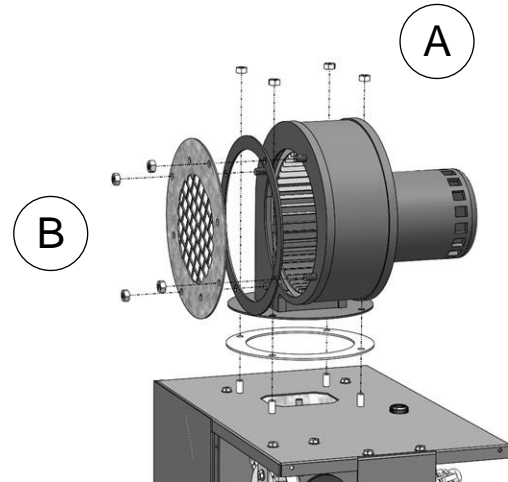

TECHNICAL DETAILS

Model	Heat Input (kW)		Partial Heat Input (kW)		Injector mm (#)	Weight kg	Dimensions (mm)		
	Gross	Net	Gross	Net			L	W	H
Natural Gas									
EUA 20 U	22.0	20.0	17.0	15.5	3.73 (#26)	66	5400	900	390
EUA 20 US	22.0	20.0	17.0	15.5	3.73 (#26)	52	3875	900	390
EUA 30 U	30.0	27.0	23.0	20.5	4.39 (#17)	66	5400	900	390
EUA 40 U	43.5	39.0	32.0	29.0	5.41 (#3)	82	6950	900	390
EUA 50 U	52.5	47.5	40.0	36.0	5.79 (#1)	114	10000	900	390
EUA 60 U	61.0	55.0	44.5	40.0	6.35 (#E)	129	11480	900	390
EUA 10 L	11.0	10.0	8.5	8.0	2.64 (#37)	46	3400	400	390
EUA 20 L	22.0	20.0	17.0	15.5	3.73 (#26)	64	9500	400	390
EUA 20 LS	22.0	20.0	17.0	15.5	3.73 (#26)	55	7975	400	390
EUA 30 L	30.0	27.0	23.0	21.0	4.39 (#17)	64	9500	400	390
EUA 40 L	43.5	39.0	32.0	29.0	5.41 (#3)	80	12550	400	390
EUA 50 L	52.5	47.5	40.0	36.0	5.79 (#1)	112	18650	400	390
EUA 60 L	61.0	55.0	44.5	40.0	6.35 (#E)	127	21700	400	390
Propane									
EUA 20 U	21.5	19.5	16.5	15.0	2.49 (#40)	66	5400	900	390
EUA 20 US	21.5	19.5	16.5	15.0	2.49 (#40)	52	3875	900	390
EUA 30 U	29.5	27.0	23.0	21.0	2.95 (#32)	66	5400	900	390
EUA 40 U	40.0	36.5	31.0	27.5	3.45 (#29)	82	6950	900	390
EUA 10 L	10.5	10.0	8.5	7.5	1.85 (#49)	46	3400	400	390
EUA 20 L	21.5	19.5	16.5	15.0	2.49 (#40)	64	9500	400	390
EUA 20 LS	21.5	19.5	16.5	15.0	2.49 (#40)	55	7975	400	390
EUA 30 L	29.5	27.0	23.0	21.0	2.95 (#32)	64	9500	400	390
EUA 40 L	40.0	36.5	31.0	27.5	3.45 (#29)	80	12550	400	390

TECHNICAL DETAILS – ErP Directive

Information required for ecodesign (ErP) Directive 2009/125

Model	EUA	10 L	20 L	20L S	30 L	40 L	50 L	60 L	20 U	20U S	30 U	40 U	50U	60U	
Natural Gas															
Heat Input (Net)	P _{nom}	kW	10	20	20	27	39	47.5	55	20	20	27	39	47	55
	P _{min}	kW	8	15.5	15.5	21	29	36	40	15.5	15.5	20.5	29	36	40
Heat Input (Gross)	P _{nom}	kW	11	22	22	30	43.5	52.5	61	22	22	30	43.5	52	61
	P _{min}	kW	8.5	17	17	23	32	40	44.5	17	17	23	32	40	44.5
Useful Efficiency (GCV)	η _{th, nom}	%	83.7	83.3	78.6	81.0	81.0	81.7	79.6	84.0	78.4	81.7	80.9	79.7	79.6
	η _{th, min}	%	82.3	81.7	74.5	79.3	77.9	80.0	76.7	82.5	76.0	78.9	78.2	77.6	76.7
Radiant Factor	RF _{nom}	%	67.5	67.5	67.5	67.5	67.5	67.5	67.5	67.5	67.5	67.5	67.5	67.5	67.5
	RF _{min}	%	63.7	63.7	63.7	63.7	63.7	63.7	63.7	63.7	63.7	63.7	63.7	63.7	63.7
Envelope Loss Factor	F _{env}	%	n/a	n/a	n/a	n/a	n/a	n/a	n/a	n/a	n/a	n/a	n/a	n/a	n/a
Control type	Two-stage														
Electrical Power Consumption	el _{max}	kW	0.07	0.07	0.07	0.07	0.07	0.07	0.07	0.07	0.07	0.07	0.07	0.07	0.07
	el _{min}	kW	0.07	0.07	0.07	0.07	0.07	0.07	0.07	0.07	0.07	0.07	0.07	0.07	0.07
	el _{sb}	kW	0.00	0.00	0.00	0.00	0.00	0.00	0.00	0.00	0.00	0.00	0.00	0.00	0.00
Ignition losses	P _{pilot}	kW	n/a	n/a	n/a	n/a	n/a	n/a	n/a	n/a	n/a	n/a	n/a	n/a	n/a
NOx seasonal (gross)		(mg/kWh)	109	114	116	117	127	128	132	114	116	117	127	128	132
Seasonal Space Heating Energy Efficiency	η _s	%	82.9	83.3	76.0	81.0	80.2	82.1	80.0	84.1	77.3	80.9	80.4	80.5	80.0

Propane

Heat Input (Net)	P _{nom}	kW	10	19.5	19.5	27	36.5			19.5	19.5	27	36.5		
	P _{min}	kW	7.5	15	15	21	27.5			15	15	21	27.5		
Heat Input (Gross)	P _{nom}	kW	10.5	21.5	21.5	29.5	40			21.5	21.5	29	40		
	P _{min}	kW	8.5	16.5	16.5	23	31			16.5	16.5	23	31		
Useful Efficiency (GCV)	η _{th, nom}	%	82.9	85.3	80.3	81.0	81.5			85.7	80.3	84.0	81.9		
	η _{th, min}	%	82.6	83.8	77.7	79.3	78.8			84.3	77.7	82.6	79.4		
Radiant Factor	RF _{nom}	%	67.5	67.5	67.5	67.5	67.5			67.5	67.5	67.5	67.5		
	RF _{min}	%	63.7	63.7	63.7	63.7	63.7			63.7	63.7	63.7	63.7		
Envelope Loss Factor	F _{env}	%	n/a	n/a	n/a	n/a	n/a			n/a	n/a	n/a	n/a		
Control type	Two-stage														
Electrical Power Consumption	el _{max}	kW	0.07	0.07	0.07	0.07	0.07			0.07	0.07	0.07	0.07		
	el _{min}	kW	0.07	0.07	0.07	0.07	0.07			0.07	0.07	0.07	0.07		
	el _{sb}	kW	0.00	0.00	0.00	0.00	0.00			0.00	0.00	0.00	0.00		
Ignition losses	P _{pilot}	kW	n/a	n/a	n/a	n/a	n/a			n/a	n/a	n/a	n/a		
NOx seasonal (gross)		(mg/kWh)	145	127	149	120	127			127	149	120	127		
Seasonal Space Heating Energy Efficiency	η _s	%	83.3	85.6	79.1	81.0	80.9			86.1	79.1	84.4	82.6		

NOTES

WARRANTY

SERIES EUA INFRARED HEATERS

WARRANTY

The manufacturer warrants to the original owner that the product will be free of defects in material and workmanship as described below.

Series	Component	Warranty Period	
		3 Years	7 Years
EUA	Burner & Controls	x	
	Heat Exchanger		x

The Manufacturer's obligation under this warranty is limited to repair or replacement, F.O.B. its facility, of the defective part. In the case of replacement parts, the warranty period shall be the longer of the original warranty or a period of 12 months from the date of purchase. In no event shall the Manufacturer be liable for incidental expense or consequential damages of any kind.

This warranty does not cover any shipping, installation or other costs incurred in the repair or replacement of the product. No materials will be accepted for return without authorization.

This warranty will not apply if in the judgment of the Manufacturer, the equipment has been improperly installed, unreasonably used, damaged or modified.

This warranty will not apply to damage to the product when used in corrosive atmospheres and in particular atmospheres containing halogenated hydrocarbons. No person is authorized to assume for the Manufacturer any other warranty, obligation or liability.

THE REMEDIES PROVIDED FOR IN THE ABOVE EXPRESS WARRANTIES ARE THE SOLE AND EXCLUSIVE REMEDIES. NO OTHER EXPRESS OR IMPLIED WARRANTIES ARE MADE INCLUDING, BUT NOT LIMITED TO, ANY IMPLIED WARRANTY OF MERCHANTABILITY OR FITNESS FOR A PARTICULAR USE OR PURPOSE.